

GB847 - Mekanord

STATUS	På lager
REF. NR.	GB847
MANUFACTURE	Mekanord
TYPE	337 HS
RED.	5,11:1
FABRIKS NR.	7 280
YEAR	2003
VESSEL	Katrine Kim
REMARKS	Clutch press 24 bar. Oil cap 30 L

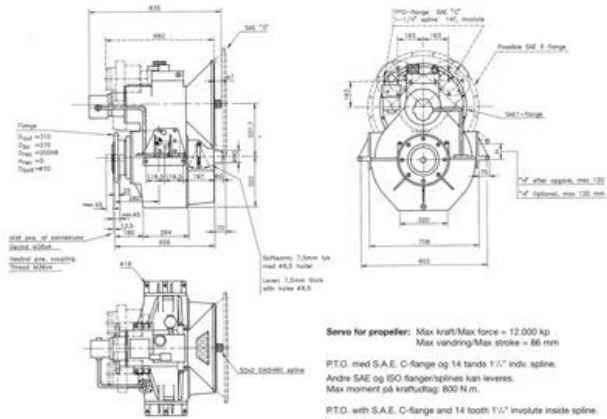





Servo for propeller: Max kraft/Max force = 12.000 kg
Max vanding/Max stroke = 86 mm

P.T.O. med S.A.E. C-fange og 14 tands 1 1/2" indre splines.
Andre SAE og ISO fanger/splines kan leveres.
Max moment på kraftudtag: 800 N.m.

P.T.O. with S.A.E. C-flange and 14 tooth 1 1/2" involute inside spline.
Other S.A.E. and ISO flanges/splines available.
Max torque from P.T.O.: 800 N.m.

Vægt/Weight: 550 kg excl. P.T.O.
600 kg incl. P.T.O.

Reduktionsforhold/ Reduction Ratio	kW / o.min. kW / RPM	HP r/min.
5,94:1	0,204	0,278
5,11 - 4,55 - 4,11 - 3,5:1	0,222	0,30

- Stort økonomisk reduktionsforhold.
- Indbygget servo for C.P.-propeller.
- Kompakt konstruktion med kort bygglængde.
- Mulighed for 1 eller 2 P.T.O. med egen hydraulisk kobling.
- Stift støbejernhus med S.A.E. 1 flange mod motor.
- Skål, slebne tandhjul i hærdet højlegeret stål.
- Hydraulisk mangepladekobling.
- Olieystem med direkte drevet pumpe, olieleder, filter, ventiler etc.
- Tryksmurt sfæriske rullelejer.
- Gearet er konstrueret iht. Klasseselskabernes krav.
- Hvert gear afprøves og kontrolleres i prøvebank.

- Large economical reduction ratio.
- Built-in servosystem for C.P. propeller.
- Compact design with short building length.
- Optional 1 or 2 P.T.O.'s with own hydraulic clutch.
- Rigid cast iron house with S.A.E. 1 flange towards the engine.
- Helical gearwheels in case-hardened and grinded highly alloyed steel.
- Hydraulic multiplate clutch.
- Oilystem with direct driven oilpumps, cooler, filter, valves etc.
- Pressure lubricated spherical rollerbearings.
- The gear is designed according to the rules of the classification societies.
- Each gearbox is tested and controlled in testbench.