

AEM - Three-phase synchronous generators - Catalogue 2011

Contents (for selecting click on text)

- 1 General**
 - 1.1 Standards and regulations
 - 1.2 Brief technical features
 - 1.3 Other typical features

- 2 Mechanical and electrical implementation**
 - 2.1 General construction
 - 2.2 Types of construction
 - 2.3 Drive and coupling
 - 2.4 Degrees of protection
 - 2.5 Cooling
 - 2.6 Stator
 - 2.7 Rotor
 - 2.8 Bearings
 - 2.9 Terminal box and connections
 - 2.10 Sequence of terminals and direction of rotation
 - 2.11 Star point connection
 - 2.12 Excitation device
 - 2.12.1 Compounding system (Types SE)
 - 2.12.2 Direct regulation (Types SH)
 - 2.12.3 Compounding system (Types SEH)

- 3 Features and operating performance**
 - 3.1 Voltage and frequency
 - 3.2 Continuous power output and overload capacity
 - 3.3 Marine classification
 - 3.4 Efficiency
 - 3.5 Voltage form
 - 3.6 Static voltage behaviour, voltage setting range
 - 3.7 Dynamic voltage behaviour
 - 3.8 V/f-regulation
 - 3.9 Short-circuit behaviour
 - 3.10 Asymmetric load
 - 3.11 Static inverter load
 - 3.12 Parallel operation
 - 3.12.1 Synchronisation
 - 3.12.2 Starting synchronisation
 - 3.12.3 Parallel operation of AEM Generators
 - 3.12.4 Parallel operation of identical AEM Generators
 - 3.12.5 Parallel operation with generators of other manufacturers
 - 3.12.6 Mains parallel operation
 - 3.13 Self-excitation
 - 3.14 De-excitation
 - 3.15 Overvoltage protection and emergency manual operation
 - 3.16 Behaviour at underspeed
 - 3.17 Vibrations
 - 3.18 Noises

- 4 Generator protection**
- 5 Modifikations and accessories**
- 6 Spare parts**
- 7 Enquiries and order data**
- 8 Rated data and measurements**
 - 8.1 View of symbols
 - 8.2 Rated data
 - 8.2.1 General notes for the following tables of rated data
 - 8.2.2 Rated data: 4-pole, 1500/1800 rpm, 85 - 4100 kVA, PF = 0.8
 - 8.2.3 Rated data: 6-pole, 1000/1200 rpm, 132 - 3700 kVA, PF = 0.8
 - 8.2.4 Rated data: 8-pole, 750/900 rpm, 110 - 4200 kVA, PF = 0.8
 - 8.2.5 Rated data: 10-pole, 600/720 rpm, 200 - 3700 kVA, PF = 0.8
 - 8.2.6 Rated data: 12-pole, 500/600 rpm, 200 - 2500 kVA, PF = 0.8
 - 8.3 Sizes and types of construction
 - 8.3.1 Size SE 315, type of construction B 3
 - 8.3.2 Size SE 400, type of construction B 3
 - 8.3.3 Size SE 450, type of construction B 3
 - 8.3.4 Size SE 500, type of construction B 3
- 9 Delivery and performance programme**

1 General

AEM Generators from Dessau have proved successful worldwide on all application fields. The series SH and SE synchronous generators in the brushless, electronically regulated version are machines with uniform functional and construction features:

- Integral electronic excitation device
- Low weight to power ratio
- Good efficiency performance
- High voltage stability
- Good dynamic performance at switching-on of load
- High reliability and long working life
- Service friendly
- Modifiability for special applications

The certificated Quality Assurance System according to DIN EN ISO 9001 ensures that the quality remains permanently high.

Please note that we continuously develop and improve our products. We retain the right to make changes in the interest of technical progress. All the technical information given in this document is only binding with our written confirmation.

1.1 Standards and regulations

The generators comply with the regulations according to DIN EN 60034/VDE 0530 and the harmonised EU standards. They can also be supplied in accordance with the regulations of the relevant marine classification associations (see section 3.3) and international standards.

1.2 Brief technical features

- **Power range** in total 65 to 4200 kVA, referred to the 50 Hz version;
- **Speed range** from 1500 to 375 rpm (4-pole to 16-pole);
- **Voltage:** standard values 230, 400, 690 V with 50 Hz, 450 V with 60 Hz; medium voltage up to 6900 V.
- **Frequency:** standard values 50 and 60 Hz. All 4-pole generators are generally laid out for 60 Hz. Other voltages and frequencies can be agreed;
- **Power factor:** PF = 0.8 - 1.0, differing values are linked to reduction in power;
- **Coolant temperature:** 40 °C; can be used up to 60 °C with reduction in power;
- **Installation height:** up to 1000 m above sea level, above this special power arrangements in conjunction with coolant temperature;
- **Degree of protection:** IP 23, other degrees of protection can be agreed;
- **Insulation class:** F, class H can be agreed;
- **Ventilation:** standard version self-ventilated IC 01 according to IEC 60034 with air inlet at the non-drive end and air outlet at the drive end;

1.3 Other typical features

- **Excitation equipment:** fitted with electronic regulator, self-excited, de-excitation possible;
- **Set-point adjustment:** $\pm 5\%$ of U_N , with internal set-point adjuster; remote set-point adjustment in preparation;
- **Statics:** can be adjusted up to 6% (transformer fitted);
- **Static voltage tolerance:** $< \pm 1\%$ of U_N at all power factors, independent on warming up condition and a speed drop of up to 5% of n_N ;
- **Dynamic voltage change:** $< 20\%$ at switching-on and -off of rated load;
- **Correction time:** 0.1 to 0.5 s according to power rating and number of poles;
- **Sustained short-circuit current:** $> 3 \times I_N$ in 3 phase; $> 6 \times I_N$ per phase for 3 - 5 s;
- **Asymmetric load:** permissible up to rated current per phase;
- **Damping winding:** standard;
- **Voltage form:** variation from sine wave $< 5\%$;
- **Distortion factor:** $< 3\%$ for phase/phase (standard version); $< 3\%$ for phase/zero at 2/3 chording;
- **Overload capacity:** 50% for 2 min, additionally 10% for 60 min (1 x within 6 hours);
- **Parallel operation:** AEM Generators between themselves and generators of different manufacturers by means of statics; AEM Generators of the same type also by means of a compensating line; mains parallel operation by means of statics device; mains parallel operation by means of power factor regulator
- **Emergency operation:** in case of generators with compoundising system (SE types) is possible with increased voltage tolerance range without regulator;
- **Underspeeds:** possible without limitation;
- **Bearings:** anti-friction bearings, according to frame size either as sealed bearings or open bearings with regreasing facility, slide bearings on request from frame size 400

2 Mechanical and electrical implementation

2.1 General construction

The generators consist of an internal pole main machine with a salient or solid pole rotor, an external pole - excitation machine for the transfer of the excitation power and the excitation device. The three-phase current that comes from the armature of the excitation machine is converted by means of a set of rectifiers that are fitted to the shaft at the non-drive end. The housing consists of the stator, the bearing eshields and a cowl that covers the excitation device that is fitted at the non-drive end. In standard version the terminal box is on top.

2.2 Types of construction

The types of construction are marked using abbreviated symbols acc. to IEC 60034 part 7/ DIN EN 60034-7. AEM's standard range contains the types of construction shown in table 1. Other types of construction can be provided on request.

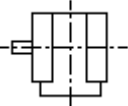
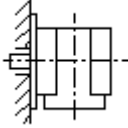
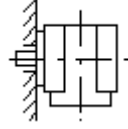
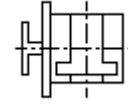
Table 1 - Types of construction		
Symbolic representation	Type of construction abbreviated symbol	Explanation
	IM B3 (B3) IM 1001	Dual bearing version with feet at the bottom and a cylindrical shaft end
	IM B20 (B20) IM 1101	as above, however, feet drawn up
	IM B35 (B3/B5) IM 2001	Dual bearing version with feet at the bottom, flange on drive-end bearing shield and a cylindrical shaft end
	IM B25 (B20/B5)	as above, however, feet drawn up
	IM B34 (B3/B14) IM 2101	Dual bearing version with feet at the bottom, flange on drive-end bearing shield and a cylindrical shaft end (flange not accessible from the rear)
	IM B24 (B20/B14)	as above, however, feet drawn up
	B16/B5	Single bearing version, with feet drawn up, flange on the drive-end bearing shield and flange shaft end or coupling disc
	B2/B5 B15/B5	as above, however, feet at the bottom

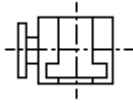
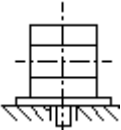
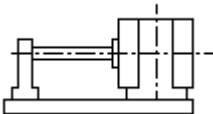
Continuation of table 1 - Types of construction		
Symbolic representation	Type of construction abbreviated symbol	Explanation
	IM B16 (B16) IM 1305	Single bearing version, with feet drawn up and a flange shaft end.
	(B15) IM 1205	as above, however, feet at the bottom
	IM V1 (V1) IM 3011	Dual bearing version for vertical application and flange on the drive-end bearing shield
	(C2) IM 6010	Dual bearing version with feet at the bottom and an external plumber block and a base plate

2.3 Drive and coupling

Since mainly piston power machines are used to drive generators the use of highly elastic couplings is recommended; their size should be selected in accordance with the permanently occurring alternating torques and according to the possible short-circuit torque.

It is recommended to calculate the torsional vibrations.

With other drives elastic couplings at least should be used. For single bearing generators that are rigidly coupled or connected by means of a coupling disc it is absolutely essential to calculate the torsional vibrations. The manufacturer will provide all the necessary generator data, moments of inertia and shaft dimensions on request.

If belt drive is to be used please contact the manufacturer so that the shaft and the bearing can be sized accordingly.

2.4 Degrees of protection

The degree of protection of the standard version is IP 23 according to IEC 60034 part 5/DIN EN 60034-5. An increased protection against oil mist and dust can be provided by use of filters at the air inlet.

Degree of protection IP 43 is implemented by the use of special filters at the drive and non-drive end.

Two options are offered for degree of protection IP 44:

- Implementation by means of pipe connection at the drive and non-drive end. The cooling air is taken out from a dust free room.
- The generator has one completely closed internal cooling circuit. The cooling air is cooled down again using external media (see table 2 - Types of cooling).

Increased protection against dust IP 54 is provided by additional bearing seals. Other degrees of protection can be agreed.

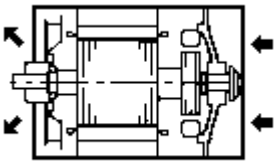
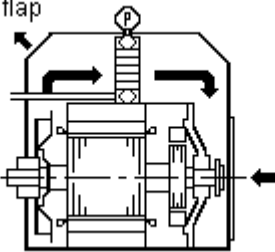
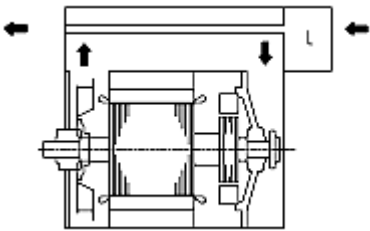
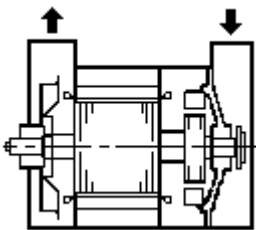
Table 2 - Types of cooling with marking according to IEC 60034 part 6 (DIN EN 60034-6), abbreviations in brackets	
	IC 0A1 (IC 01) Standard version self- cooling
emergency ventilation flap Notluft  emergency ventilation flap Notluft	IC 8A1 W7 (IC 81W) Air-water cooling
	IC 6A1 A6 (IC 616) Air-air cooling
	IC 3A1 (IC 31) Self-cooling with pipe connection

2.5 Cooling

The conventional types of cooling for AEM Generators are shown in table 2. The standard version has an IC 01 type of cooling according to IEC 60034 part 6/DIN EN 600034-6 with internal cooling and self-ventilation.

The parameters for the cooling medium (temperature, quantity, pressure, losses that have to be disposed of) have to be agreed for secondary cooling circuits.

With air-water heat exchangers it is generally possible to maintain the rated output through the sizing of the heat exchanger. Possible deviations have to be agreed.

With air-air heat exchangers an output reduction of approx. 25 % is to be expected due to the difference in temperature between the internal and external circuit.

The exact value has to be agreed.

If the secondary cooling circuit fails then a self-ventilated emergency operation is possible (approx. 80 % P_N). The emergency operation and the power during emergency operation have to be agreed.

2.6 Stator

Depending on the frame size and type of construction the stator housing is either welded or cast. Internally arranged longitudinal ribs accept the lamination pack. The feet are either welded or cast to the housing or they are screwed to the housing using the side surfaces provided. The endshield (on the drive side) is normally made of cast iron to which the SAE flanges of the standard sizes are cast on or can be screwed onto. Additionally adaptor rings are provided for adjustment purposes. Special endshields e. g. for V1 version or flange version without feet are welded. The endshield at the non-drive end is also made of cast iron. Apart from the bearing it also accommodates the stator of the excitation machine (in-side)

and the excitation device (outside). The stator windings are made of either round or flat temperature index 210 wire. Multilayer surface insulation materials of insulation class F are used as insulation. Together with the resin impregnation high mechanical, electrical and climatic durability is achieved that permits the use of the generators in all climatic areas and on board ship. Insulation according to insulation class H or special versions e.g. against chemically aggressive media is possible against enquiry.

2.7 Rotor

The rotors with the laminations are made as either salient pole rotor or solid pole rotor.

All rotors have a closed damping winding in order to satisfy the requirements during parallel operation and in order to dampen the harmonics at static inverter load. The excitation winding made of flat or round wire (temperature index 210) complies with insulation class F or if agreed class H. The coils are isolated against the iron by means of multi-layer surface insulation material and they are supported mechanically against each other.

The winding overhangs are additionally equipped with bandages and the complete rotor is impregnated with resin. The armature of the excitation machine with the three phase current winding (3) (fig. 1) is situated between the excitation winding and the non-drive end bearing.

The rotating rectifier set (5) (fig. 1) together with an over-voltage limiter is fitted outside the stator. For the mass moments of inertia of the complete rotating part (without coupling) the values according to the measurement summary (section 8.3) apply with a 10 % tolerance according to DIN EN 60034-1.

The dimensions of the shaft ends in standard versions can be obtained from the dimension tables. Special agreement must be made for shaft ends that are different and for versions with 2nd shaft end. The rotors are balanced dynamically with an inserted half key according to DIN ISO 1940 in precision class G 6.3 and for special requirements in G 2.5. They are spun with $1.2 \times n_N$. The rotors of the 4 pole generators are generally laid out for 60 Hz operation, all others can be laid out like that if required. Higher spinning speeds (e. g. transit speeds for hydro-electric power plants) have to be agreed.

2.8 Bearings

In the standard version the generators up to frame size 250 are fitted with sealed antifriction bearings.

If required the bearings can be equipped with a regreasing device with grease quantity control.

From frame size 315 regreasing devices at the drive and non-drive end are fitted as standard. Initially tensioned groove ball bearings are used, on the larger shaft heights at the drive end also cylindrical roller bearings and at the non-drive end according to load either groove ball bearings or dual bearing arrangement with groove ball and cylindrical roller bearing (initially tensioned groove ball bearings at these shaft heights can be agreed). Special bearing arrangement is provided on generators that have to comply with special requirements, such as increased working life, belt drive, vertical installation, special radial or axial forces. From frame size 400 slide bearings can be fitted.

The rotor is fixed to protect the cylindrical roller bearings during transport. This safety device has to be unlocked prior to the commissioning of the generator! For temperature monitoring either Pt 100 screw-in measuring sensors or PTC measuring sensors can be fitted. If required the release device can also be supplied.

2.9 Terminal box and connections

Normally the terminal box is situated on the stator back, it has the connections for the stator winding and all additional terminals required for the operation and monitoring of the generator. Water-tight screw cable glands are provided for the customer's connection - their number and dimensions have to be agreed. Other cable or rail gland systems have to be agreed. The terminal box situated on top can be rotated by 180 °. The stator winding in the standard version is implemented in star connection with conducted out star point. The version with 6 terminals (resolved star point) needs to be ordered specifically.

2.10 Sequence of terminals and direction of rotation

With drive direction right (clockwise, looking at the shaft end) the chronological phase sequence corresponds to the terminal sequence U - V - W as according to DIN EN 60034-8. When the direction of rotation is reversed the phase sequence changes.

The anti-clockwise direction of rotation with phase sequence U - V - W is possible and has to be stated when the order is placed. If the direction of rotation has to be reversed subsequently it is necessary to reverse the connections on the excitation device. Generators with a fan, which is dependent on the direction of rotation, demand an exchange of fans.

2.11 Star point connection

The star point conductor of the generators is sized generously in consideration of the asymmetrical load. When the generator star point is connected to the star point of other generators or to that of the mains then a compensating current with predominately threefold mains frequency can occur in the star point conductor. Under all load conditions this current should not be higher than approx. 40 % of the rated current of the generator. The compensating current can be limited by means of a choke in the star point conductor or by means of a specially implemented winding (2/3 chording) (agreement necessary).

2.12 Excitation device

According to the frame size and application two systems can be used for the excitation of the generators.

2.12.1 Compounding system for low voltage (types SE)

Figure 1 - Compounding with electronic voltage regulator

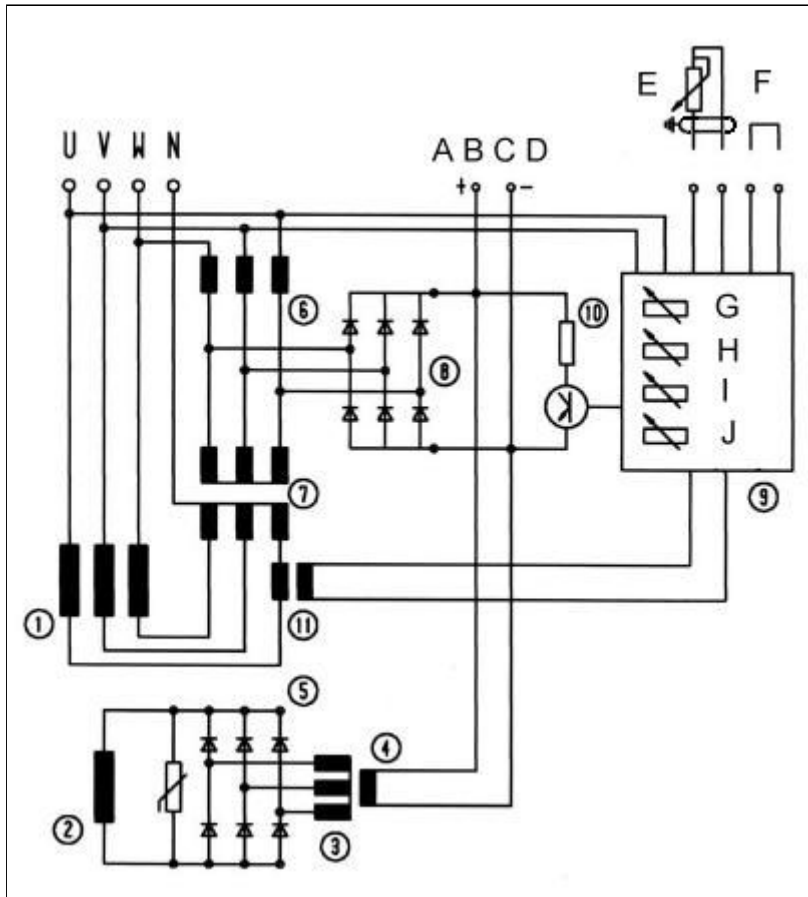

1. Stator winding
 2. Rotor winding
 3. Rotor winding of excitation machine
 4. Stator winding of excitation machine
 5. Rotating rectifier stack
 6. Choke
 7. Current transformer
 8. Stationary rectifier stack
 9. Electronic voltage regulator R10
 10. Step-down resistance
 11. Static current transformer
-
- A. Excitation
 - B. De-excitation
 - C. Emergency operation
 - D. Compensating line
 - E. Set-point adjuster
 - F. Bridge for power factor duty
 - G. Voltage
 - H. Static
 - I. Stability
 - J. Power factor (by power factor regulator only)

The voltage generated by the residual magnetism of the magnetic circuits in the stator winding (1) (see fig. 1) of the generator causes that a small current flows through the stator winding (4) of the excitation machine and initialises the self-excitation process. The choke (6) ensures that at rated speed the generator is only excited up to 1.1 of the rated voltage. When load is applied onto the generator the current transformer (7) produces an additional excitation current that depends on the load (booster effect) that is added to the choke current. After rectification in the stationary rectifier set (8) this excitation alternating current arrives at the stator winding (4) of the excitation machine. When the rated voltage of the generator is exceeded a series R10 electronic voltage regulator (9) periodically switches on the step-down resistance (10) that is situated parallel to the excitation stator winding. By this the effective current that flows through the stator winding (4) of the excitation machine is limited to a value that is necessary to adhere to the terminal voltage that has been pre-set by means of the set-point adjuster.

2.12.2 Direct regulation (types SH)

These excitation devices (see fig. 2) consist of:

- Auxiliary windings (1a)
- Electronic voltage regulator (9)

The self-excitation is based on the residual magnetism of the magnetic circuits and additional permanent magnets in the stator of the exciter (4). A voltage is induced in the auxiliary windings that are inserted in the stator grooves according to a special winding diagram. This voltage is rectified and controlled in a series R9 regulator (9) and is conducted to the stator winding of the excitation machine. The auxiliary windings are designed in such a way that there is an exciter surplus (ceiling voltage) for all possible applications. The voltage is controlled in the regulator to such an extent that such an exciter current flows that produces exactly the required terminal voltage.

Figure 2 - Direct regulation with auxiliary winding in stator

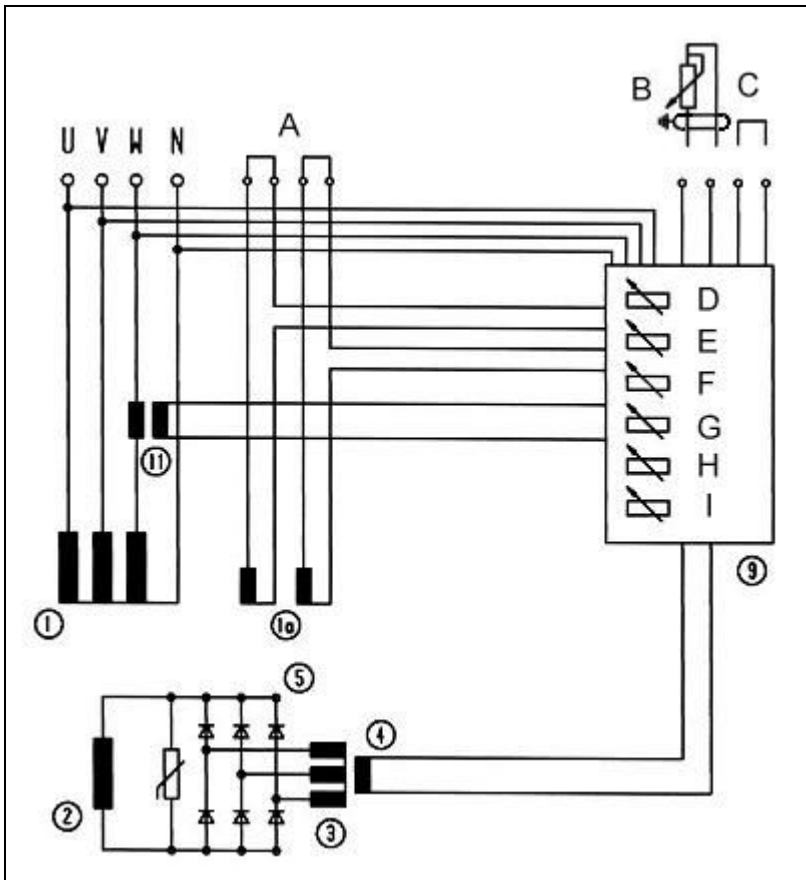

1. Stator winding
 - 1a. Auxiliary winding
 2. Rotor winding
 3. Rotor winding of excitation machine
 4. Stator winding of excitation machine
 5. Rotating rectifier stack
 9. Electronic voltage regulator R9
 11. Static current transformer
- A. De-excitation
 B. Set-point adjuster
 C. Bridge for power factor duty
 D. Voltage
 E. Static
 F. Stability
 G. V/f
 H. f_{break}
 I. Power factor (by power factor regulator only)

2.12.3 Compounding system for medium voltages (types SEH)

A modified excitation system with compounding will be used in case of generator voltages > 1 kV (s. fig. 3). An additional transformer (12) will be built in for potential cut-off and voltage adjustment.

Besides a low voltage-auxiliary winding (1a) will put in the stator, which supply the necessary choke current for excitation device. With it the whole function is in accordance with low voltage version "SE" (s. 2.12.1) just as the whole operational behaviour.

Figure 3 - Compounding for medium voltage generators

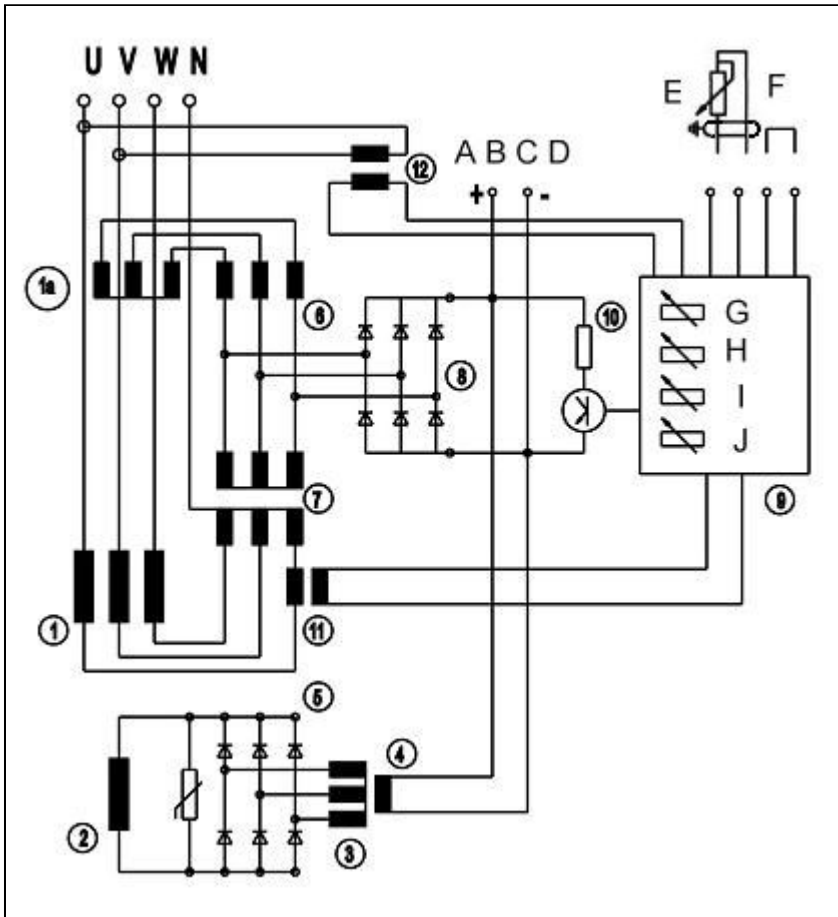

1. Stator winding
- 1a. Auxiliary winding
2. Rotor winding
3. Rotor winding of excitation machine
4. Stator winding of excitation machine
5. Rotating rectifier stack
6. Choke
7. Current transformer
8. Stationary rectifier stack
9. Electronic voltage regulator R10
10. Step-down resistance
11. Static current transformer
12. Voltage transformer

- A. Excitation
- B. De-excitation
- C. Emergency operation
- D. Compensating line
- E. Set-point adjuster
- F. Bridge for power factor duty
- G. Voltage
- H. Static
- I. Stability
- J. Power factor (by power factor regulator only)

3 Features and operating performance

3.1 Voltage and frequency

The generators are manufactured for all rated voltages recommended in the IEC directives and DIN EN 60034-1 up to 6900 V at either 50 or 60 Hz. For 230 V generators please note power according to section 3.2 Generators for special voltages and other frequencies can be supplied on request.

3.2 Continuous power output and overload capacity

The rated power outputs listed in the type summaries (section 8.2) apply for:

- Continuous operation S1 at 50 resp. 60 Hz rated frequency
- Power factor PF = 0.8 (over-excited)
- Cooling air temperature 40 resp. 45 °C
- Installation height up to 1000 m above sea level
- Practically sine form load current
- Symmetrical phase winding load

With different power factor, cooling air temperature and installation height values the permissible continuous power output can be taken from tables 3 and 4. If the cooling air temperature reduces with installation height by approx. 1 °C per 100 m then the rated power output can be retained. With any other deviations please consult the manufacturer. This applies particularly for the static inverter load (see section 3.11). Generators with 230 V can be supplied up to a power output of 630 kVA.

Table 3 - Changing of rated power output in dependence of cooling air temperature and installation height							
RT/°C	30	35	40	45	50	55	60
H/m above sea level	P_S/P_N						
up to 1000	1.06	1.03	1.00	0.96	0.92	0.88	0.84
up to 2000	1.02	0.99	0.96	0.92	0.88	0.84	0.80
up to 3000	0.97	0.94	0.91	0.87	0.83	0.79	0.75
up to 4000	0.91	0.88	0.85	0.81	0.77	0.73	0.69

Operation in ambient temperatures above 60 °C requires manufacturer approval.

Table 4 - Changing of rated power in dependence of power factor					
PF	0.7	0.6	0.5	0.4	0
P_S/P_N	0.94	0.89	0.85	0.82	0.80

Overload capacity

At rated voltage the generators can be loaded with the 1.5 x rated current up to a period of 2 min at PF = 0.5 and once within 6 hours with 1.1 x rated current for 1 hour. Short term current overloads that occur when e. g. large asynchronous motors are switching-on are permissible. The excitation device is designed in such a way that the rated voltage is retained with a tolerance of approx. - 5 %.

3.3 Marine classification

All generators for marine applications (Diesel generators, PTO generators, static frequency inverter for mains separation etc.) are supplied in accordance with the regulations of the following classification societies as standard. If supply in accordance with other classification societies is required please consult the manufacturer.

Table 5 - Reduction in power output for on board ship applications			
Organisation		Coolant temperature °C	Reduction factor to P_N
ABS	American Bureau of Shipping	50	0.92
BV	Bureau Veritas	45	0.96
CCS	China Classification Society	45	0.96
DNV	Det Norske Veritas	45	0.96
GL	Germanischer Lloyd	45	0.96
LRS	Lloyds Register of Shipping	45	0.96
MRS	Maritime Register of Shipping	45	0.96
RINa	Registro Italiano Navale	45	0.92

Compared to the dry land versions according to table 3 and table 4 the reductions in power listed in table 5 results from the increased cooling air temperature and the permissible winding temperatures laid down by the societies. For marginal applications please consult the manufacturer.

3.4 Efficiency

The efficiencies listed in the type summaries refer to the total generator losses including the excitation machine and the excitation equipment. The tolerances of DIN EN 60034-1 have to be taken into consideration for all values. If agreed generators with an increased efficiency can be supplied for special applications (in block heating power stations, hydro power generating plants etc.).

3.5 Voltage form

According to DIN EN 60034-1 the no load voltage between two phases is practically sine shaped:

- max. deviation from the sine form below 5 %;
- distortion factor of the interlinked voltage is smaller than 3 %;
- telephone harmonic factor THF up to 1000 kVA max. 5 %, up to 5000 kVA max. 3 %.

If the phase voltage between phase and star point has to be practically sine shaped as well (e.g. for emergency power plant) then the generator windings are implemented in a 2/3 chording factor. Generally this means a reduction in power of approx. 10 %.

3.6 Static voltage behaviour, voltage setting range

The set point of the generator voltage will be kept constant on load from no load up to rated load at power factors 0 to 1.0 with a tolerance of 0.5 to 1.0 %. This accuracy applies for operation without static device independently on the warming up condition of the generator and a max. 5 % speed modification of the driven machine. The rated voltage can be modified by means of a set-point adjuster on the regulator and/or in the control panel by ± 5 %. The setting range can be increased and this has to be agreed.

The regulator can be supplied with an input for ± 5 V for the adjustment of the voltage set-point.

3.7 Dynamic voltage behaviour

Sudden changes of load are always inevitably followed by short time voltage changes (see fig. 4).

These voltage changes depend on the level of current change, on the power factor and on specific machine parameters. Thus when the rated power is switched-on with a rated power factor then the voltage dip is approx. 15 - 20 % of the rated voltage. The stabilisation period t_A depends on the frame size and speed of the generator and is between 0.2 and 0.5 s.

Through the compounding system or selection of a high ceiling voltage of the auxiliary winding it is ensured that the rated voltage is reached again quickly.

Guide values for the voltage dip $\Delta U'$ in dependence on the starting current and power factor can be seen in the diagram in fig. 5. Here it has been assumed that the load is switched-on to the generator that is running without load at rated voltage and that the speed remains constant. If the switching-on of load a noticeably preloaded generator then the voltage dip reduces slightly. The diagram applies for 4-pole generators at 50 Hz. For generators with a higher number of poles the values have to be multiplied by 1.1, the same applies for 60 Hz version. If agreed generators with special design for shock load switchings-on with reduced voltage dip can be supplied.

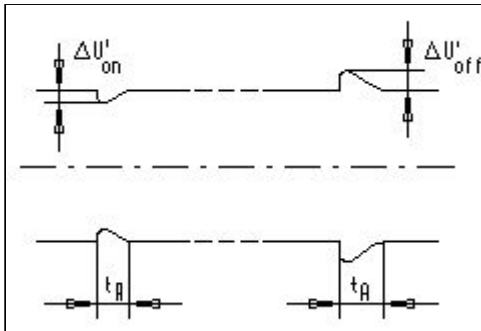

Figure 4

Voltage deviation by switching on and off of load

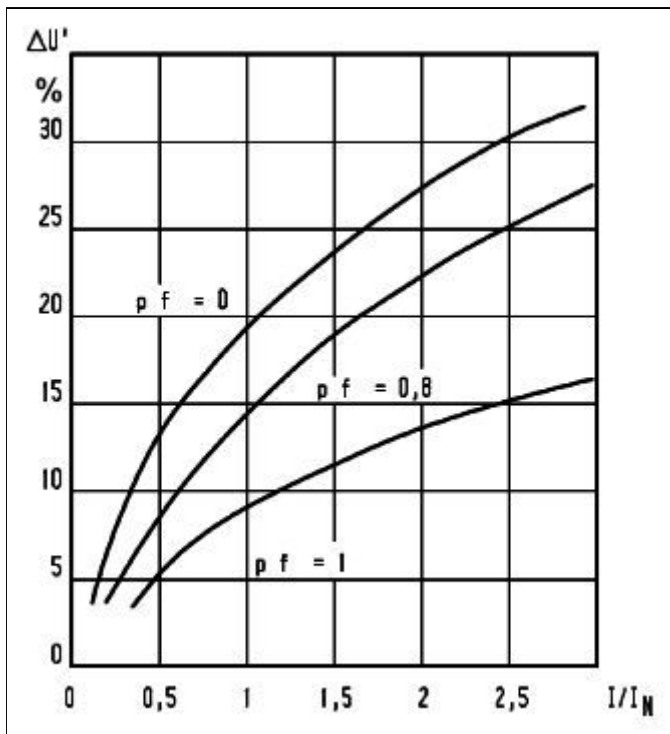

Figure 5

Voltage dip in dependence of starting current and power factor

Switching-on of asynchronous motors

Special dynamic loads occur when large asynchronous motors with squirrel-cage rotors are switched-on. Through the compounding system with higher current the excitation is also increased so that the switching-on of asynchronous motors is only limited by the drive and the switchgear with the connected loads. Short time voltage reductions up to 20 % do not cause any problems under normal circumstances.

If relatively large squirrel-cage motors have to be switched-on directly then the following circumstances have to be taken into consideration when the plant is designed and the set is selected:

- Is the driving machine of the generator capable of producing the increased generator drive power short time at a certain starting factor of the asynchronous motor?
- How big can the voltage dip become without affecting voltage dependent loads, switchgears etc. in a detrimental way?
- Will the torque of the asynchronous motor be sufficient at voltage dips during the start?
- Guide values for the switching-on of asynchronous motors are as follows:
 - Motor power/kW approx. 15 % of the generator type power/kVA: $\Delta U'$ ca. 20 %
 - Motor power/kW approx. 30 % of the generator type power/kVA: $\Delta U'$ ca. 30 %
 - With star/delta-connection three times the motor powers can be used.

In special drive applications the following start up methods are recommended:

Frequency start-up

If the generator is supplying an asynchronous motor that has nearly the same power then the full speed running can be achieved by switching-on when the Diesel set is at a standstill. Subsequently the Diesel engine is started and gradually run up to its rated speed. With increasing speed excitation of the generator takes place and it takes the asynchronous motor along with it up to its rated speed.

Voltage start-up

The de-excitation of the generator takes place at full speed (see section 3.14). The asynchronous motor is switched-on in a condition without voltage or with reduced voltage and excitation of the generator takes place again. The motor starts up with increasing voltage.

NOTE:

In both cases the prerequisite is a separate mains for the motor and start-up without counter-torque or with fan or pump curve and also a constant auxiliary voltage for the switchgear.

Switching-on of transformer

Voltage start-up should be selected for transformers with the same power in order to avoid the starting current.

3.8 V/f-regulation

The R10-KF regulator permits a frequency proportional voltage regulation below the rated speed.

Below a break frequency the generator voltage sinks. Above this value the voltage does not depend on frequency.

When a load is switched-on to a Diesel set then a short dip of the generator voltage occurs and the speed reduction of the motor. Since the stabilization period for the voltage is considerably shorter than the stabilization period for the speed (approx. 1 : 10) the switched-on electrical load is practically constant without influencing the voltage whilst the counter-torque for the motor increases additionally because of the speed reduction.

Contrary to that the frequency dependent voltage regulation removes the load from the motor during the stabilization phase and reduces the stabilization period. Figure 6 shows the progression of the voltage, torque and speed with and without V/f-regulation. When large loads in proportion to the driving motor power are switched-on - specifically with motors with turbo loaders - there is the possibility to improve the load take-over behaviour of the Diesel sets and to increase the permissible switching-on power. The R10-KF regulator can be fitted onto the SE types subsequently without modifications.

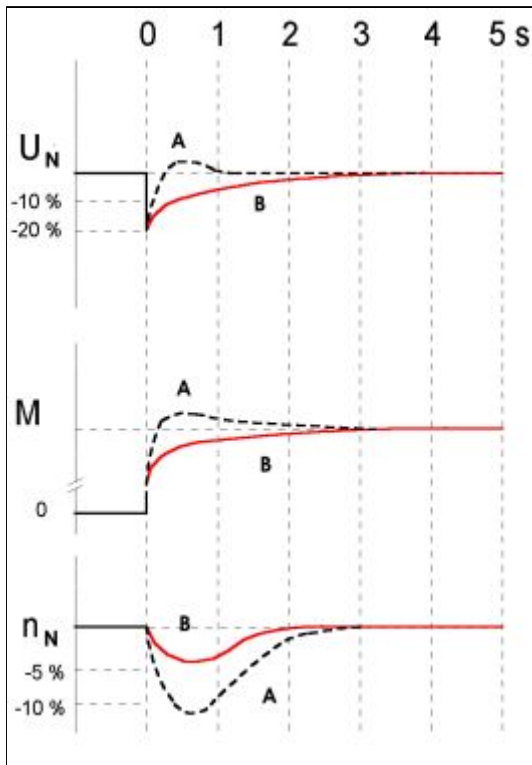

Figure 6

Voltage (U_N), torque (M) and speed (n_N) behaviour by switching-on with (A) and without (B) V/f-regulation

3.9 Short-circuit behavior

The peak asymmetric short-circuit current complies with DIN EN 60034-1. The required short-circuit protection of the generators is ensured. Please consult us if you require generator data for the short-circuit calculation.

With a three-phase terminal short-circuit the generator produces a stable sustained short-circuit current of at least $3.5 \times I_N$.

The sustained short-circuit current has to be switched-off after a maximum of 5 s.

The two-phase short-circuit current is approx. 1.5 times and the one-phase approximately 2 times of the three-phase sustained short-circuit current.

The peak asymmetric short-circuit current dies away quickly and transforms into the sustained short-circuit current after approx. 100 - 150 ms.

In order to adhere to the protective measures a sustained short-circuit current of up to $5 \times I_N$ may be necessary in special cases. In these cases please consult us for special agreement.

NOTE:

Short-circuit currents are absolute values that refer to the rated powers; please take into consideration at power reductions!

3.10 Asymmetric load

It is permissible to supply asymmetric mains as long as the current does not exceed the rated value in any phase. Here it has to be taken into consideration that the voltage deviation, voltage form and the power data no longer reach the rated values. Thus the voltage asymmetry is approx. $\pm 5\%$ with a single phase load with rated current and two no-load phases or with two phase rated current and one no-load phase. To ensure optimum operating conditions an as even as possible division of the currents onto the three phases should always be aimed at.

3.11 Static inverter load

Static inverters are non-linear loads the connection of which leads to a distortion of the voltage curve, which results in increased generator losses and which possibly impaired the functionality of the other connected loads. In order to keep the consequences of the static inverter load as small as possible the generators are designed in a special way for this. An effective damper winding, 2/3 chording, particularly small subtransient reactances (x_d'') and according to the type of load also a larger generator type ensure an optimum operation.

Prerequisite for the sizing is the knowledge of the plant that is being designed. If possible the following should therefore be stated when placing the order:

- Portion of the static inverter load of the total load
- Current distortion factor
- Inverter type (3, 6, 12 phase inverter)
- Type of the static inverter load (drives, telecommunications equipment, battery loading etc.)
- Permissible voltage distortion factor of the plant

Guide values for the sizing of the generator are as follows:

- Inverter 12 pulse approx. 80 %,
- Inverter 6 pulse approx. 70 %,
- Inverter for variable speed approx. 50 % of the rated power with standard winding.

3.12 Parallel operation

All generators have a damper cage and are designed for parallel operation. Through the fitted statics device the voltage curves in dependency on load current and power factor receive a slightly falling characteristic to the power proportional reactive load distribution. The voltage statics can be set up to a max. of 6 % (referred to PF = 0.8). The prerequisite for a stable parallel operation with power proportional active load division is that the speed regulator of the driving machines is designed accordingly.

3.12.1 Synchronisation

The parallel connection of the generators can be performed using the known synchronisation methods. The voltage, frequency and phase position have to be brought in line.

Following deviations before the interconnection are permissible:

- Voltage difference max. 10 % of U_N
- Frequency deviation max. 2 % of f_N
- Error angle max. 15° between the zero transits of the voltages

ATTENTION!

Since mechanical damage can occur on the generator and the set please ensure that false synchronisations are avoided at all times.

3.12.2 Starting synchronisation

Certain mains replacement plant must be capable of operation for max. of 15 s, i.e. after mains failure the emergency power supply must take over the complete power output within this period of time. For plant with several sets this period of time is not sufficient for the driving machines to reach the full speed, for excitation to take place and for the subsequent synchronisation to be carried out. This can be shortened considerably by using start-up synchronisation. With generators of the SE series the start-up synchronisation for the same generators is possible. (With different types please consult the manufacturer.) In this case the generators are connected parallel by means of a compensating line prior to the start (s. 3.12.4) and are run up to speed jointly, during which they pull themselves in a synchronous phase position at excitation, and afterwards load is applied.

3.12.3 Parallel operation of AEM Generators

Table 6 - Actual operating diagram of gensets		
Measure	Effect in single operation	Main effect in parallel operation
Voltage set point of generator ↑	Generator voltage ↑	Generator supply more reactive power
Voltage set point of generator ↓	Generator voltage ↓	Generator supply less reactive power
Speed set point of drive ↑	Frequency ↑	Generator supply more active power
Speed set point of drive ↓	Frequency ↓	Generator supply less active power

Parallel operation of generators of any type is ensured with the aid of the statics device. The statics of approx. 2 % (referred to the no-load voltage; at rated current and power factor PF = 0.8) that is set in the factory ensures a correct parallel operation. Thus the required even distribution of the reactive load onto the individual generators is achieved. The statics can be set using the relevant potentiometer on the regulator. No additional measures are required on the switchgear.

3.12.4 Parallel operation of identical AEM Generators

This is possible without any problems using a compensating line. For this the stator windings of the excitation machines have to be joined after synchronisation. A proportional active load division leads inevitably to a corresponding reactive load distribution. The voltage tolerance remains unchanged compared to single operation. The statics are not necessary.

3.12.5 Parallel operation with generators of other manufactures

For this the generators must have a damper cage and the excitation device must be suitable for parallel operation. A correct distribution of the reactive load requires that all generators have a statics device and practically corresponding falling voltage curves can be set.

NOTE:

If the star points are connected then it may be necessary to fit a choke in the star point conductor in order to avoid incorrect compensating currents.

3.12.6 Mains parallel operation

To ensure a stable parallel operation of a genset with rigid mains it is necessary to avoid an overload at changing mains conditions and at the same time utilise the power to the highest possible extent. As far as the active load is concerned this is done by means of the speed regulator or an electronic load distribution. As far as the reactive load is concerned it can be carried out either by means of the statics device or by means of a power factor dependent regulation (PF regulation / please take the power limitation according to table 4 into consideration!)

Regarding the limitation of the current in the star point conductor see section 2.11.

- **Mains parallel operation with statics**

In order to prevent reactive power overload of a generator at the mains the generator voltage must be lowered by the statics device at increasing reactive load (also see section 3.12.).

- **Mains parallel operation with PF regulator** (R10-KC, R9-C regulator)

At constant operation at mains a special PF regulator can be supplied for reactive current regulation. Apart from the normal voltage regulation it also allows the regulation of the power factor PF independently on the active load of the genset and on the changes of the mains voltage at the infeed point. A PF regulator can also be fitted subsequently without any modifications being required.

3.13 Self-excitation

This occurs through remanence in the magnetic circuit of the excitation machine. On start up the excitation of the generator to the rated voltage is carried out through this within approx. 2 - 5 s. In special cases the build-up can be shortened by e.g. special construction or when an external voltage is applied short time to the stator winding of the excitation machine.

3.14 De-excitation

The generator de-excite with the running machine if:

- On the SE types with compounding device the lead-out terminals (+,-) of the stator winding of the excitation machines are short circuited;
- On the SH types with direct regulation the auxiliary winding are switched off on the terminals in the terminal box.

On the generator terminals there remains only a residual voltage at the rate of the remanence voltage.

3.15 Overvoltage protection and emergency manual operation

- The compounding principle with step down regulation that is used for the excitation of the SE types has the advantage that in the event of the regulator failing the excitation current is limited by the choke and the voltage cannot exceed the 1.1 times rated value.
If a spare regulator is not available then an emergency operation at a voltage deviation of approx. $\pm 3\%$ that is not limited in time can be implemented. To do this a variable resistance (approx. $150\ \Omega$, 2 A) has to be connected in parallel to the stator winding of the excitation machine after the regulator has been disconnected; this can be used to set the required voltage. Further instructions are contained in the operating instructions for the excitation device.
- On the generator types with direct regulation (SH types) a fuse in the regulator protects the generators against an excessive voltage increase in the event of the regulator failing. The generator is de-excited when the fuse responds. An emergency manual control can be implemented by connecting a settable external voltage of approx. 50 V DC.

3.16 Behaviour at underspeed

Underspeeds of the driving machine (e.g. warm up running, measurements on motor) are possible without any time limitations:

- On the SE types the choke limits the excitation current so that even without V/f-regulation a speed dependent terminal voltage appears. A load application onto the generator at partial speeds is possible with limitations due to the reduced ventilation.
- On the SH types with direct regulation the regulator contains a V/f-function that limits the excitation current in dependency on the speed (frequency) and deregulates the terminal voltage

3.17 Vibrations

In the standard version the generators comply with vibration severity grade A according to DIN EN 60034-14. Version in grade B can be agreed.

3.18 Noises

The limit values according to DIN EN 60034-9 are complied with.

4 Generator protection

- **Thermal winding protection**

PTC sensors according to DIN 44081 can be fitted to protect the stator winding against thermal overload. Pt100 measurement sensors can be fitted to monitor the winding temperature or for protection purposes. The triggering devices can be supplied if agreed.

- **Anti-condensation heaters**

It is recommended to fit anti-condensation heaters to prevent condensation during longer down-times for generators for marine applications or for use in tropical regions. Unless otherwise agreed the connection voltage of the anti-condensation heaters is 220/230 V. According to frame size the heater output is as follows:

Shaft height [mm]	Heater output [W]
315, 400	150
450, 500	300
630	520
710	780

- **Cooling air filter**

If required a cooling air filter can be fitted. Normally the power output is then reduced by approx. 5 %. It is absolutely necessary to provide a thermal winding protection in order to prevent overheating in the event of the filter becoming dirty.

- **Protection and measurement transformer**

If current transformers for protection or measuring purposes are required then a consultation about the type and possible free issue supply are necessary.

- **Bearing monitoring**

PTC sensors or Pt100 measurement sensors can be fitted to protect the bearings against thermal overload. The triggering devices can be supplied if agreed.

On request vibration pick-ups (SPM nipples) can be installed for monitoring of bearing condition or bearing housing can be prepared for installation.

SPM nipples can be screwed on the bearing housing, in countersunk threaded holes.

5 Modifications and accessories

Types of construction that deviate from the basic types of construction:

- SAE flange, special flange
- Intermediate flange SAEx in SAEy
- Special shaft, 2nd shaft end
- Belt drive
- Bearing shield with connecting piece for pipe connection or air outlet upward / downward
- External ventilation with or without filter
- Hydro power version with increased runaway speed
- Non-standard terminal box, non-standard position, 6 terminals
- Non-standard stator winding
- Non-standard voltage up to 1000 V and/or non standard frequency
- Reactive or asymmetric load version
- Increased efficiency (e.g. for block heating power stations)
- Special outputs, output increase
- Climatic protection in extreme climatic conditions protection against acids and bases
- Marine classification
- Vibration severity grade B according to DIN EN 60034-14
- Increased balancing quality
- Version for mail operation
- Unregulated version with +3 to -5 % voltage deviation
- Increased voltage setting range
- Fitted emergency operation resistance
- Special regulation requirements (e.g. PF-regulation, V/f-regulation)
- External set-point adjuster
- Regulator for switch panel fitting
- Input for ± 5 V of the voltage set point
- Increased sustained short-circuit current (up to 5 times)
- Starting synchronisation
- Frequency start-up for large asynchronous motors
- Version as synchronous motors
- Motor generator set driven by electric motor
- Wind power generators
- 3 to 6 temperature sensors for protection of stator winding (PTC or Pt100, trigger device for sensor optional)
- Anti-condensation heaters
- Screw-in temperature sensors for bearing monitoring
- Vibration pick-up for bearing monitoring
- Star point choke for limitation of the neutral wire current for fitting into switch panel
- Air filters
- Increased degree of protection
- Star point transformer for differential protection and other instrument transformers
- Slide bearings
- Insulated bearings
- Assembled (add-on) air - water heat exchangers (single or double pipe heat exchanger)
- Assembled (add-on) air - air heat exchanger
- Speed monitoring

6 Spare parts

Independently from the spare parts specified by the classification societies or other regulations the following spare parts are recommended to guarantee a high utilisation of the generators:

- 1 set of anti-friction bearings
- 1 regulator
- 1 stationary rectifier
- 1 rotating rectifier (instead of the rotating rectifier individual modules can be ordered for the rectification and overvoltage protection)

Further spare parts can be purchased using the spare parts catalogue that forms part of the documentation and referring to the type designation and the serial number of the generator.

7 Enquiries and order data

In order to be able to process your enquiries and orders as quickly as possible we require information with regard to the points listed below:

Driving machine

- Type (e. g. electric motor, internal combustion machines with stroke and cylinder number, turbine etc.)
- Power (HP, kW)
- Speed (rpm)

Generator

- Power (kW or kVA)
- Voltage (V)
- Frequency (Hz)
- Runaway speed (rpm)
- Max. speed (rpm)
- Direction of rotation (anti-clockwise or clockwise)
- Type of construction
- and if possible information about:
 - Dimensions
 - Power factor
 - Cooling air temperature
 - Installation height
 - Speed static
 - Classification regulations
 - Position of the terminal box and cable glands
 - Temperature monitoring of the winding and the bearings (PTC or Pt100)
 - Single and parallel operation
 - Mains parallel operation
 - Anti-condensation heaters
 - Static inverter load (see section 3.11)
 - Protection transformer (with free issue?)
 - Other special conditions

8 Rated data and measurements

8.1 View of symbols

P_N	=	Rated power in kVA
P_S	=	Apparent power in kVA
P_W	=	Active power in kW
η	=	Efficiency in %
$2p$	=	Number of poles
n	=	Speed in rpm
n_N	=	Rated speed in rpm
I	=	Current in A
I_N	=	Rated current in A
U_N	=	Rated voltage in V
m	=	Weight in kg
J	=	Mass moment of inertia in kgm^2
RT	=	Room temperature in $^{\circ}\text{C}$
PF	=	Power factor
H	=	Maximum installation height in m above sea level
$lcl.$	=	Insulation class
$S1, S10$	=	Types of duty according to DIN EN 60034 - 1

8.2 Rated data

8.2.1 General notes for the following tables of rated data

- Marine design in acc. to ABS, BV, DNV, RINa with approx. power reduction of 5 %
- By 2/3 chording design approx. 10 % power reduction
- By air filter installation approx. 5 % power reduction
- Data like weights, mass moments of inertia, partial load efficiencies, reactances as well as measures on special request.
- Modified powers especially in border range are to agree on special request.

8.2.2 Table 7 - Rated data: 4-pole, 1500/ 1800 rpm, 85 - 4100 kVA, PF = 0,8

Type	Rated power [kVA], S1, Incl. F					
	400 V, 50 Hz			450 V, 60 Hz		
	40 °C	45 °C	η (%)	40 °C	45 °C	η (%)
SE 315 SA4	250	240	92,7	300	285	93,3
S4	280	270	92,8	345	330	93,7
M4	330	320	93,8	400	380	94,1
L4	420	400	94,5	500	480	94,8
LL4	520	500	94,8	630	600	95,3
SE 400 S4	650	630	94,4	770	750	94,4
M4	820	800	95,1	990	960	95,3
L4	1030	1000	95,6	1240	1200	95,7
LL4	1240	1200	95,9	1440	1400	96,1
SE 450 M4	1300	1250	95,6	1600	1560	95,9
L4	1600	1560	95,9	1800	1750	96,1
SE 500 S4	1950	1900	95,3	2310	2250	95,6
M4	2360	2300	95,9	2820	2750	96,1
L4	2680	2600	96,1	3150	3050	96,2
SE 630 S4	3250	3150	96,1	3700	3600	96,4
M4	3700	3600	96,4	4100	4000	96,6

8.2.3 Table 8 - Rated data: 6-pole, 1000/1200 rpm, 132 - 4200 kVA, PF = 0,8

Type	Rated power [kVA], S1, Incl. F					
	400 V, 50 Hz			450 V, 60 Hz		
	40 °C	45 °C	η (%)	40 °C	45 °C	η (%)
SE 315 SA6	140	132	92,1	170	160	92,8
S6	170	160	93,0	210	200	93,3
M6	210	200	92,4	250	240	93,5
L6	260	250	93,4	310	300	94,0
LL6	310	300	94,1	375	360	94,3
SE 400 S6	410	400	92,8	515	500	93,2
M6	515	500	92,8	615	600	93,5
L6	645	630	93,5	770	750	94,0
LL6	820	800	94,0	985	960	94,5
SE 450 M6	975	950	94,2	1130	1100	94,9
L6	1130	1100	94,9	1340	1300	95,3
SE 500 S6	1390	1350	95,3	1700	1650	95,1
M6	1600	1560	94,9	1950	1900	95,5
L6	1850	1800	95,2	2250	2200	95,4
LL6	2150	2100	95,6	2560	2500	95,8
SE 630 S6	2360	2300	95,5	2770	2700	95,8
M6	2670	2600	95,9	3230	3150	96,1
L6	3180	3100	96,0	3700	3600	96,4
LL6	3700	3600	96,2	4200	4100	96,4

8.2.4 Table 9 - Rated data: 8-pole, 750/900 rpm, 110 - 4200 kVA, PF = 0,8

Type	Rated power [kVA], S1, Incl. F					
	400 V, 50 Hz			450 V, 60 Hz		
	40 °C	45 °C	η (%)	40 °C	45 °C	η (%)
SE 315 SA8	115	110	89,8	140	132	90,7
S8	140	132	91,1	170	160	92,0
M8	170	160	91,9	200	190	92,5
L8	210	200	92,1	240	230	92,9
SE 400 SA8	260	250	93,2	310	300	93,7
S8	330	320	93,6	410	400	94,1
M8	410	400	94,1	495	480	94,6
L8	515	500	94,1	615	600	94,7
SE 450 M8	645	630	94,5	770	750	94,8
L8	820	800	94,8	985	960	95,0
SE 500 S8	1040	1000	95,3	1250	1200	95,2
M8	1300	1250	96,0	1550	1500	95,3
L8	1540	1500	95,4	1850	1800	95,8
LL8	1850	1800	95,7	2150	2100	96,0
SE 630 SA8	2050	2000	95,9	2460	2400	96,1
S8	2250	2200	96,0	2670	2600	96,3
M8	2460	2400	96,5	2870	2800	96,4
L8	2770	2700	96,4	3200	3100	96,4
SE 710 SA8	3000	2900	96,1	3450	3350	96,4
S8	3300	3200	96,4	3800	3700	96,7
M8	3700	3600	96,5	4200	4100	96,8

8.2.5 Table 10 - Rated data: 10-pole, 600/ 720 rpm, 200 - 3700 kVA, PF = 0,8

Type	Rated power [kVA], S1, Icl. F					
	400 V, 50 Hz			450 V, 60 Hz		
	40 °C	45 °C	η (%)	40 °C	45 °C	η (%)
SE 400 S10	205	200	91,5	250	240	92,2
M10	260	250	92,4	310	300	92,9
L10	325	315	93,1	410	400	93,6
SE 450 S10	410	400	93,2	495	480	93,7
M10	515	500	93,8	615	600	94,5
SE 500 S10	645	630	94,2	770	750	94,7
M10	820	800	94,9	985	960	95,1
L10	1030	1000	94,8	1230	1200	95,0
SE 630 SA10	1290	1250	95,3	1600	1560	95,5
S10	1600	1560	95,6	1850	1800	95,6
M10	1850	1800	95,6	2200	2150	95,9
L10	2150	2100	95,8	2460	2400	95,9
SE 710 SA10	2460	2400	95,7	2920	2850	96,1
S10	2770	2700	96,0	3250	3150	96,3
M10	3100	3000	96,2	3700	3600	96,4

8.2.6 Rated data: 12-pole, 500/600 rpm, 200 - 2500 kVA, PF = 0,8

Technical data and measurements for these generators and for generators higher number of poles on special request.

8.3 Sizes and types of construction

8.3.1 Size SE 315, type of construction B 3

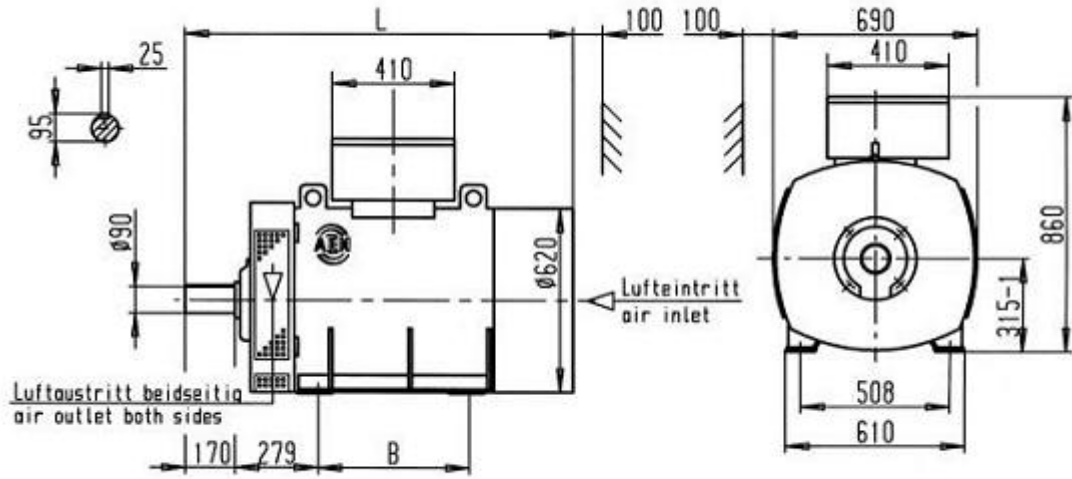

Shaft end acc. to IEC 60072-1

Terminal box rotatable by 180°

Subject to alteration

Other measurements and types of construction acc. to requirement

Type	Number of poles	Weight [kg]	J [kgm ²]	L [mm]	B [mm]
SE 315 SA	4	850	4,2	1310	508
	6	800	5,4		
	8	800	6,1		
SE 315 S	4	950	4,9	1310	508
	6	900	6,2		
	8	900	7,2		
SE 315 M	4	1100	5,9	1310	508
	6	1050	7,4		
	8	1050	8,5		
SE 315 L	4	1300	7,7	1420	508
	6	1250	8,9		
	8	1200	10,4		
SE 315 LL	4	1500	9,0	1535	630
	6		11,1		

8.3.2 Size SE 400, type of construction B 3

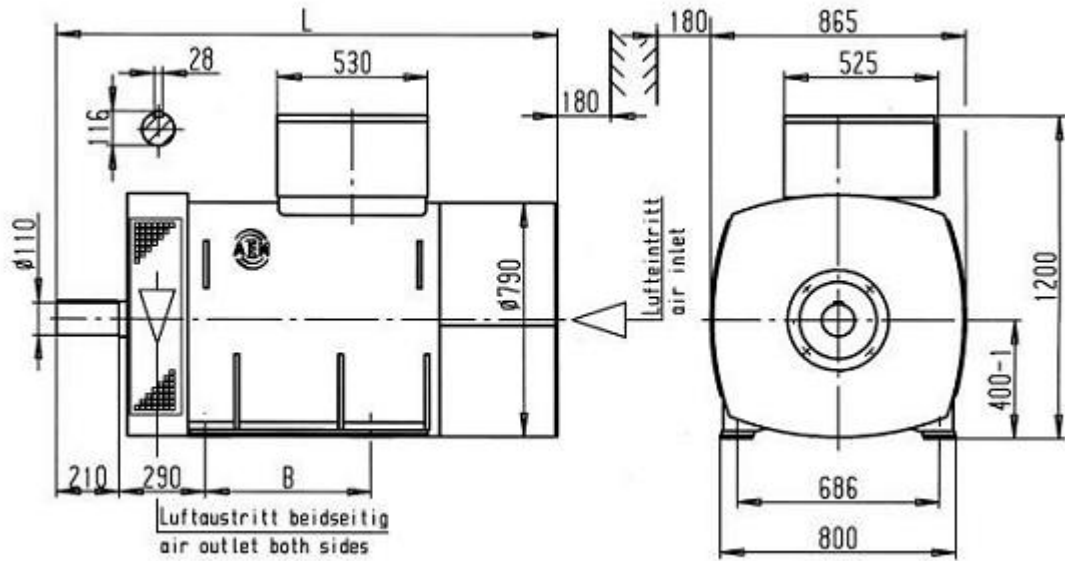

Shaft end acc. to DIN IEC 60072-2

Terminal box rotatable by 180°

Subject to alteration

Other measurements and types of construction acc. to requirement

Type	Number of poles	Weight [kg]	J [kgm ²]	L [mm]	B [mm]
SE 400 S	4	1800	13,8	1690	560
	6	1900	21,6		
	8	1500	21,3		
	10	1500	18,1		
SE 400 M	4	2300	20,3	1780	630
	6	2000	25,7	1690	
	8	1650	25,0		
	10	1650	22,0		
SE 400 L	4	2600	24,3	1890	710
	6	2200	31,2	1780	630
	8	2000	31,1		
	10	2000	31,0		
SE 400 LL	4	2800	28,0	2000	855
	6		41,7		

8.3.3 Size SE 450, type of construction B 3

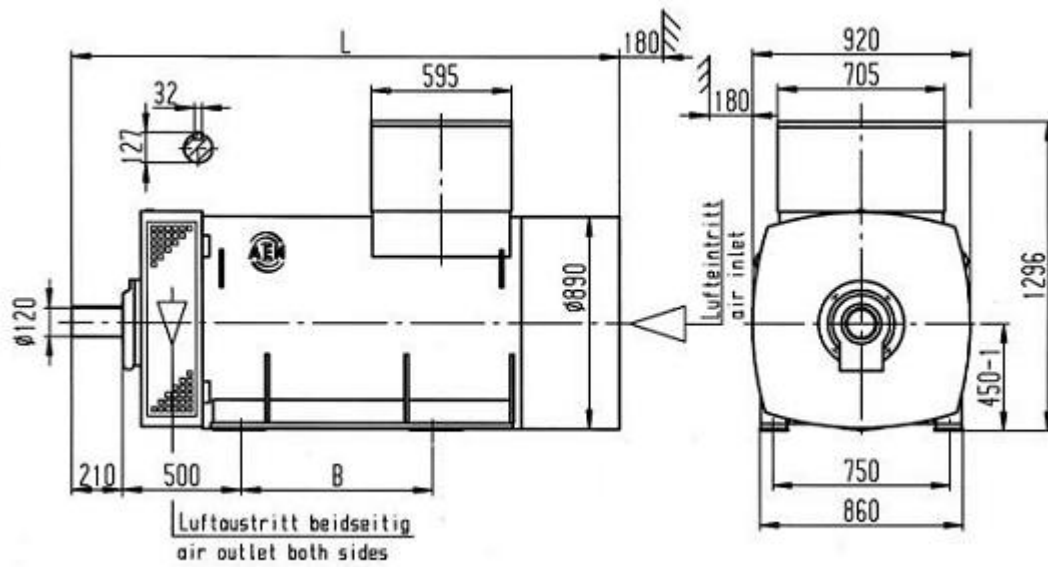

Shaft end acc. to DIN IEC 60072-2

Terminal box rotatable by 180°

Subject to alteration

Other measurements and types of construction acc. to requirement

Type	Number of poles	Weight [kg]	J [kgm ²]	L [mm]	B [mm]
SE 450 S	10	2700	31,2	1990	630
SE 450 M	4	3200	34,8	2295	800
	6	3200	56,3		
	8	3000	38,2	1990	630
	10	3000	37,5		
SE 450 L	4	3600	40,4	2295	800
	6	3700	67,8		
	8	3400	47,8		

8.3.4 Size SE 500, type of construction B 3

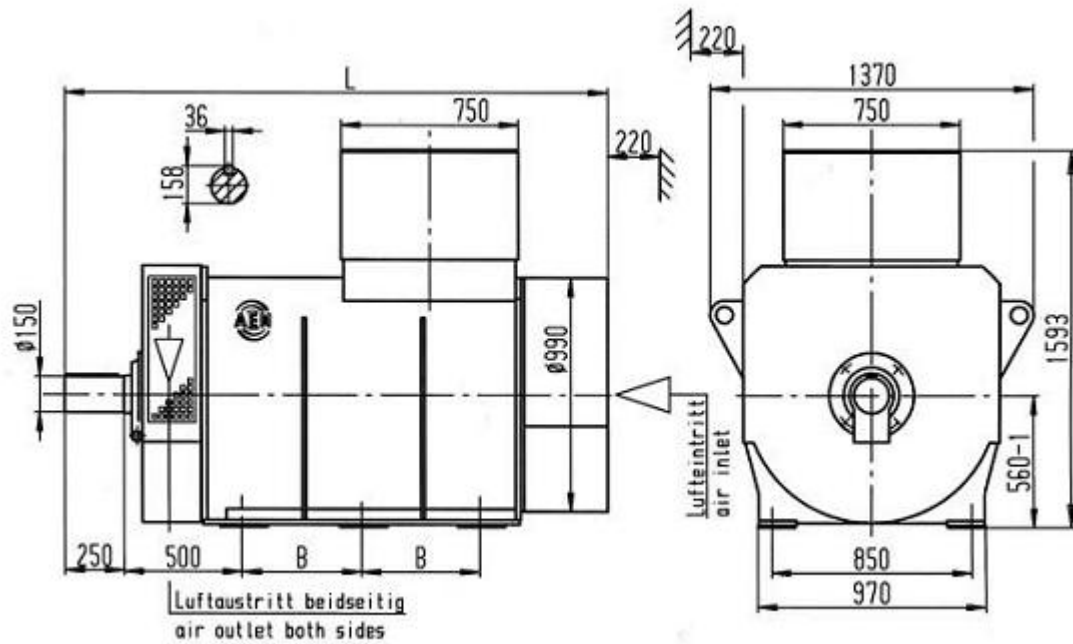

Shaft end acc. to DIN IEC 60072-2

Terminal box rotatable by 180°

Subject to alteration

Other measurements and types of construction acc. to requirement

Type	Number of poles	Weight [kg]	J [kgm ²]	L [mm]	B [mm]
SE 500 S	4	4800	66,0	2550	500
	6	4400	98,1	2400	
	8	4400	91,0	2400	
	10	3800	100,0	2020	
SE 500 M	4	5100	76,0	2700	
	6	4800	118,3	2550	
	8	4800	103,1	2400	
	10	4200	116,0	2400	
SE 500 L	4	5800	87,0	2700	
	6	5700	127,5	2700	
	8	5800	123,2	2550	
	10	5000	127,0	2550	
SE 500 LL	6	6300	144,3	2700	
	8	6200	136,5		

9 Delivery and performance programme

- **Three-phase synchronous generators**

Low voltage and medium voltage up to 6900 V,
4- to 16-pole, 250 - 4200 kVA, IP 23

- **Asynchronous generators on request**

- **Three-phase asynchronous motors** - Low voltage up to 1000 V

Squirrel-cage rotors, 2- to 12-pole

surface ventilated	200 - 2000 kW ¹⁾	IP 55
tube-cooled	630 - 2000 kW ¹⁾	IP 55
open-circuit ventilated	160 - 3500 kW ¹⁾	IP 23
water-jacketed cooled	132 - 2800 kW ¹⁾	IP 55

Slip-ring rotors²⁾, 4- to 12-pole

surface ventilated	200 - 1000 kW ¹⁾	IP 55
tube-cooled	630 - 1700 kW ¹⁾	IP 55
open-circuit ventilated	160 - 1700 kW ¹⁾	IP 23

- **Three-phase asynchronous motors** - Medium voltage up to 6600 V

Squirrel-cage rotors, 2- to 12-pole

surface ventilated	132 - 1400 kW ¹⁾	IP 55
tube-cooled	500 - 1560 kW ¹⁾	IP 55
open-circuit ventilated	200 - 2800 kW ¹⁾	IP 23
water-jacketed cooled	132 - 2000 kW ¹⁾	IP 55

Slip-ring rotors²⁾, 4- to 12-pole

surface ventilated	110 - 1000 kW ¹⁾	IP 55
tube-cooled	500 - 1560 kW ¹⁾	IP 55
open-circuit ventilated	200 - 1750 kW ¹⁾	IP 23

- **Special machines and modifications**

in a.m. power range on request

- **Submersible motors on customer's request**

- **Rotating converters**

¹⁾ All power values related to the 4-pole version (1500 rpm)

²⁾ Water-jacketed cooled slip-ring rotors on request