

HYDRECO

HYDRAULIC SOLUTIONS PROVIDER

1600 SERIES GEAR PUMPS AND MOTORS



12.38 TO 41.3 CM³/REV.
170 BAR. PRESSURE

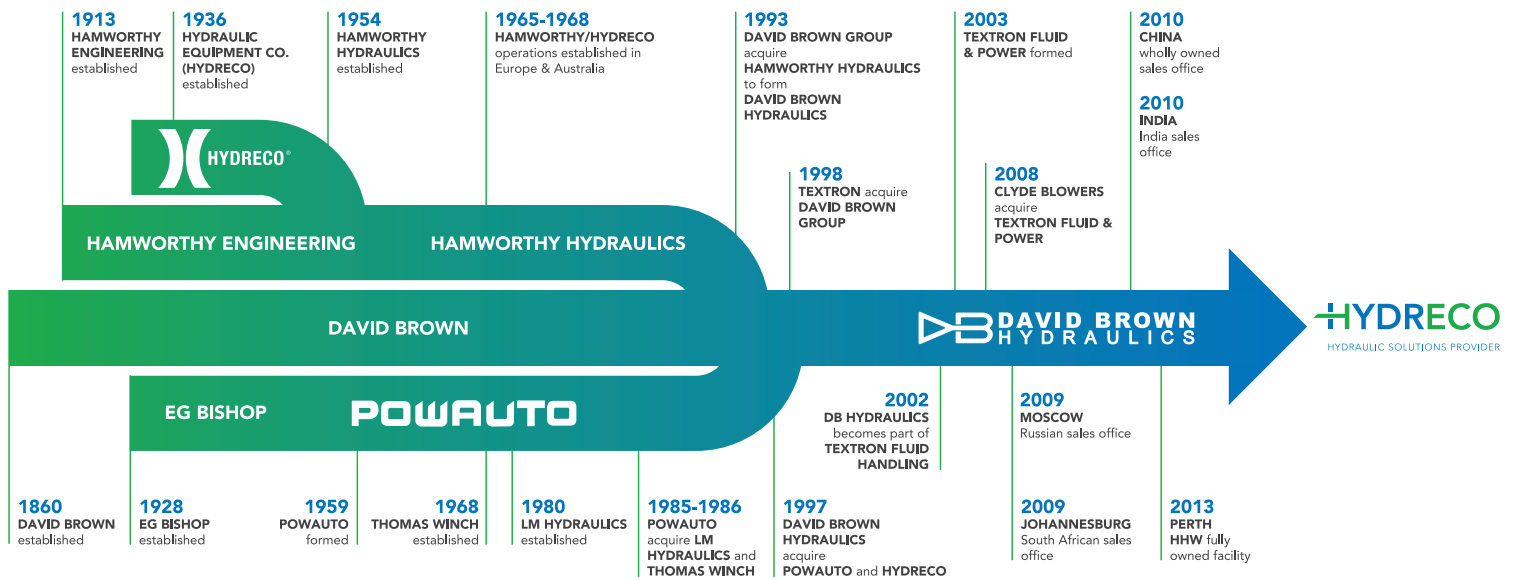

100 YEARS OF HYDRAULICS EXPERIENCE

Hydreco Hydraulics is the designer, manufacturer and distributor of products servicing the transport and mobile hydraulics sector. Hydreco has a combined history of 100 years in developing solutions through a rich heritage of legacy companies. The joining of David Brown Hydraulics, Powauto and Hydreco in 1997 brought together some of the most respected products, people and heritage brands in the business.

Engineering excellence is at the core of our organization, the product range is geared towards offering the best possible solution for many applications within Construction, Earth moving, Transport, Industrial, Materials handling, and many more. We pride ourselves on supporting customers through leading edge products, designed to provide optimum performance and extensive reliability in continual hard working applications. With innovative technology our products have evolved and developed, leading to a range of some of the highest quality products available in the market

place. The business is positioned to respond to your hydraulic needs through a worldwide network of manufacturing and sales facilities.

Hydreco has an extensive range of low noise helical gear, aluminium and cast iron gear pumps and standard spur gear models from its David Brown heritage. Its valve range covers multi-spool sectional and monoblock models with electro hydraulic, hydraulic and lever control. Dual axis, stackable and single axis hydraulic pilot valves, with an extensive range of handle options including ergonomic handles with many switches and button options. The valves are available with spring centred and electric detent options.

Under the name Hydreco Powauto, with heritage back to 1928, we sell our range of Transport hydraulics products. The product range covers power take-off units, pumps, valves, cylinders and accessories for on and off road vehicles. This World Class brand possesses a strong footprint in Asia Pacific building on its excellent reputation.



The manufacturing engineering office from the 1950's



The Tool Room from 1947

OPERATION NOTES

All components are designed to operate within the limits of performance of an Average Production Unit as stated herein.

For operations outside the Standard specification it is essential that prior approval be obtained from **Hydreco Hydraulics**.

The Company's Terms of Warranty are specified on our written quotations, and are also available separately on request.

Dirt, metal particles and other contaminants are harmful to all precision built hydraulic components.

Always ensure that the system is initially clean and fluid cleanliness is maintained at ISO.4406 16/11 (optimum), 19/15 (max).

Before pressurising the Pump, Motor or Control Valve, confirm that:

- ▶ All pipes and fittings are properly installed and connected.
- ▶ The system is filled with fluid of the correct specification.

Servicing Instructions and spare Parts Sheets for all **Hydreco Hydraulics** units are available from our Service Department.

Features marked* are preferred standard.

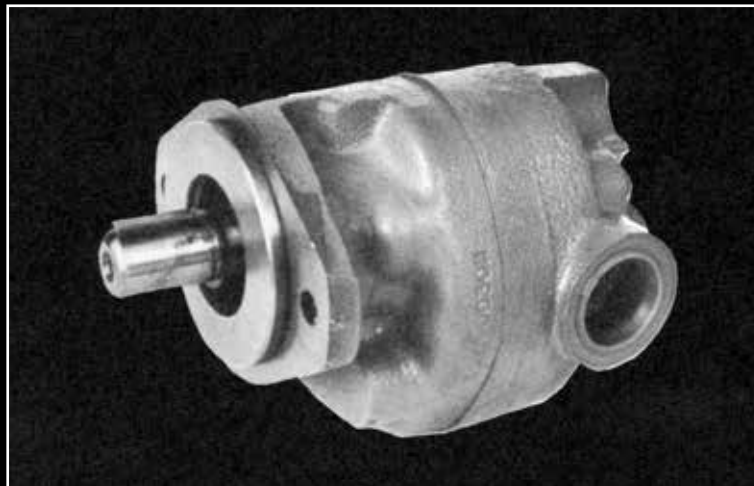

1600 GENERAL DATA

INTRODUCTION

The information contained in this leaflet covers all 1600 Series Gear Pumps and Motors forming part of the wide range of Hydraulic Pumps, Motors, Control and Auxiliary Valves produced by **Hydreco Hydraulics** (see page 15).

Our extensive coverage is specifically designed to provide manufacturers of construction equipment and mechanical handling plant with the best possible combination of pumps, motors and control equipment at competitive prices.

The high rate of technical innovation demanded by equipment manufacturers constantly adds new features to our products, usually as the result of intensive practical development undertaken to improve the operation or economics of a specified type of machine. Such features cannot always be covered in a publication of this nature but our application engineers are always ready to help in finding a practical solution.

Hydraulically, your business is our business and we believe our company to be uniquely qualified to assist you to get the best out of your machines. This professional technical service is freely at your disposal.

Our fully equipped plant provides us with the most up-to-date production facilities in Europe. Qualified distributors or subsidiary companies in the most important industrial markets, ensure that parts and service are available internationally.

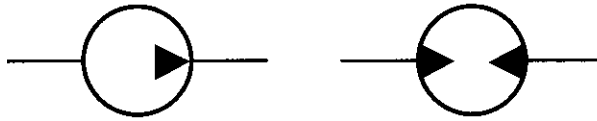

THEORETICAL DISPLACEMENT

Units	1604	1606	1608	1610	1613	1617
cm ³ /rev	12.38	14.6	19.4	24.3	31.6	41.3

GENERAL DATA

Drive Shafts	See Page 6
Shaft Seal Designs	See Page 6
Mounting Flanges	See Page 7
Port Connections	See Page 7
Rotation - Pumps	Either direction (not reversible)
Rotation - Motors	Either direction (reversible)
Speed Range Pumps	500-2700 rev/min
Speed Range Motors	500-3000 rev/min
Dimensions	See Page 6
Weight	See Page 6
Mounting Position	No attitude limitation
Ambient Temperature Range	-20°C to +60°C
Hydraulic Fluid Temperature Range	-20°C to +80°C
Maximum viscosity for Cold Start	850mm ² /sec (cSt)
Maximum for normal working conditions	250mm ² /sec (cSt)
Minimum permissible viscosity	10mm ² /sec (cSt)
For optimum 'life' and efficiency, fluid viscosity should be in the range of 15 to 25mm ² /sec (cSt) during normal working conditions.	
Performance Data	} See Pages 9-14
Overall Efficiencies	
Pressure/Speed Limitations	

OPERATING PRESSURE - PUMPS

Inlet Pressure Range	Minimum	See Page 5
	Maximum	2 bar
	Outlet 1604 to 1610	170 bar (max)
	1613 to 1617	155 bar (max)

OPERATING PRESSURE - MOTORS

Inlet/Outlet	1604 to 1610	170 bar (max)
	1613 to 1617	155 bar (max)
Drain Line Pressure		Maximum 2 bar

ALL DATA IS OBTAINED FROM AVERAGE PERFORMANCE OF REGULAR PRODUCTION PUMPS USING GOOD QUALITY S.A.E. 10 MINERAL HYDRAULIC OIL AT 50°C. GENERALLY CORRESPONDING TO A VISCOSITY OF 23 mm²/sec (cSt).

Critical Dimensions of all Shafts, Flanges and Ports conform to S.A.E. Standards where these are specified.

1600 GENERAL DATA

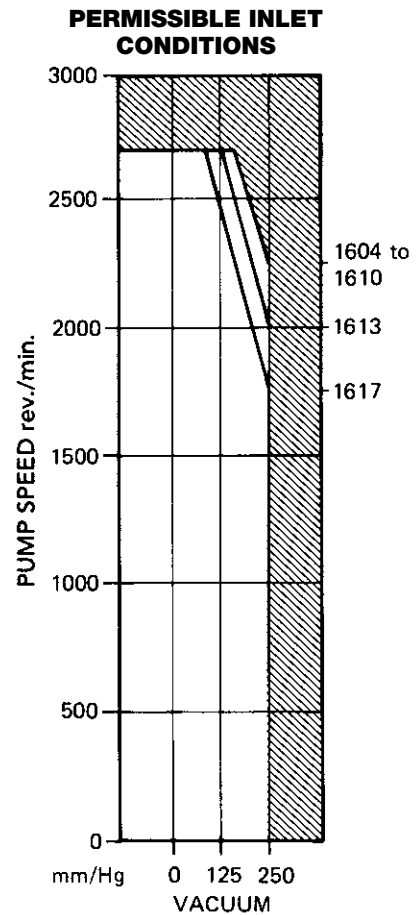
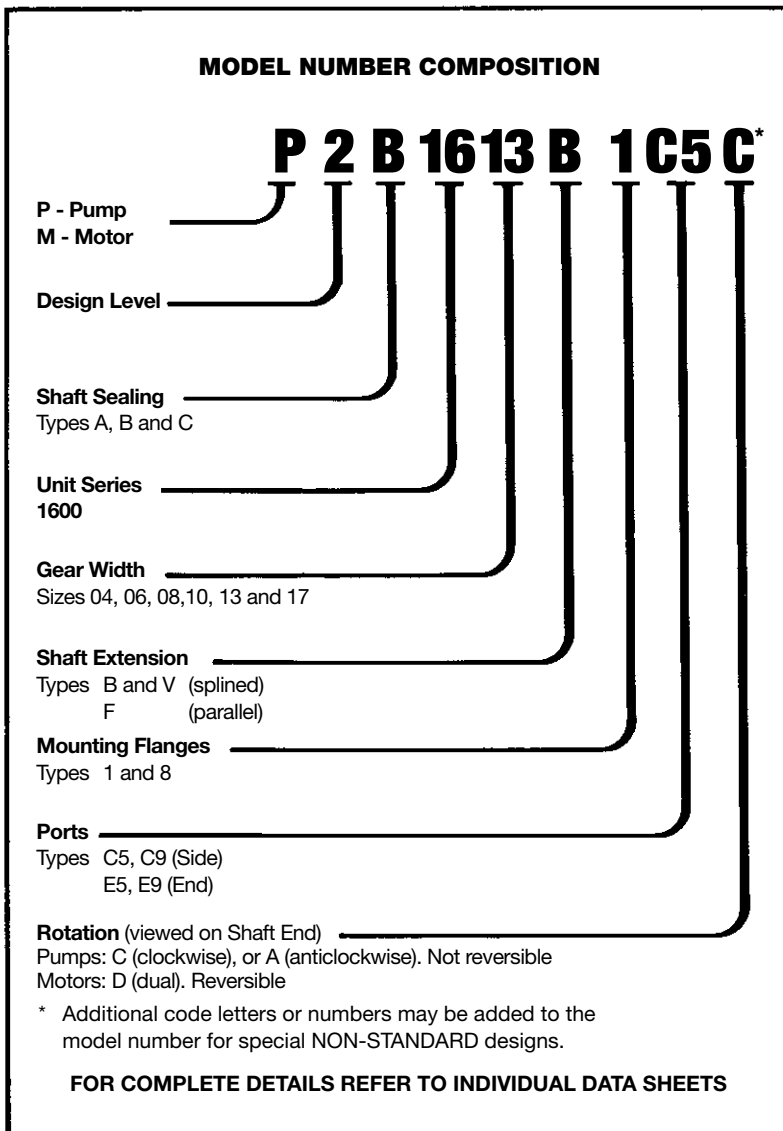

Pumps with standard size ports will operate without detriment when inlet conditions are within the outlined area of the chart. For operation within the shaded area, consult **Hydreco Hydraulics**.

DRIVE SHAFT POWER LIMITATIONS

The shafts listed below are recommended for use where the horsepower to be transmitted at any given speed lies within the shaded areas of the accompanying graph,- for requirements outside these limitations refer to **Hydreco Hydraulics**.

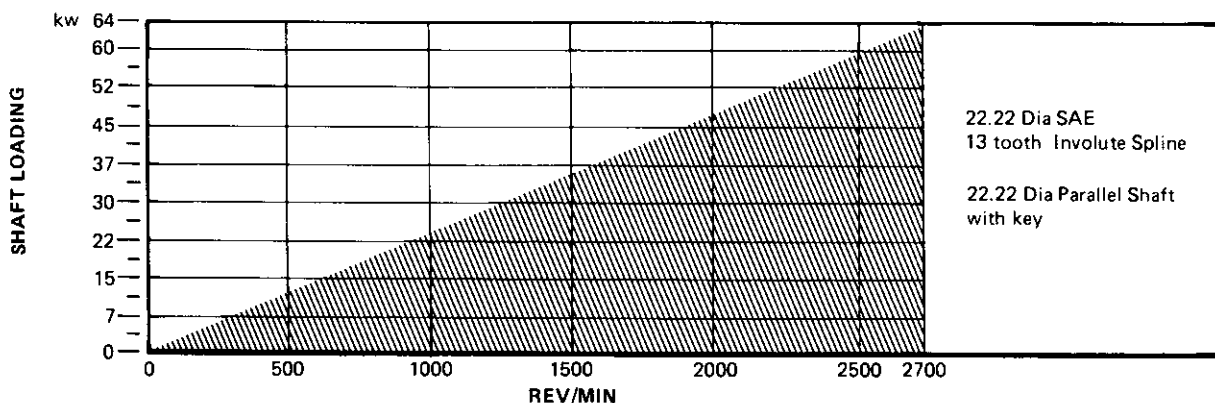

1600 GENERAL DATA

GENERAL DIMENSIONS (mm)

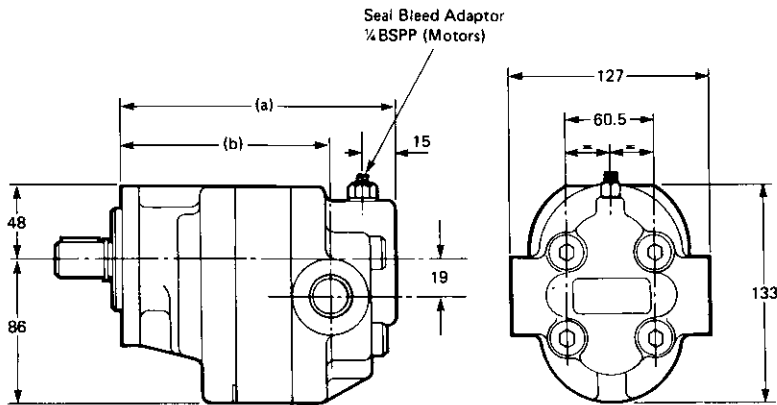

NOTE: Illustration shows side ported unit. For port details see page 6.

DIMENSIONS (a) & (b) CHANGE WITH ADAPTOR & HOUSING

UNIT SIZE	SIDE PORTS 'C'		TOP PORTS 'L'		END PORTS 'E'		WEIGHT (kg)
	(a)	(b)	(a)	(b)	(a)	(b)	
1604	145	113	145	113	157	157	7.3
1606							
1608	150	118	150	118	160	160	7.7
1610	154	122	154	122	165	165	8.6
1613	162	130	162	130	173	173	9.1
1617	172	140	172	140	183	183	9.5

C of G position
Approx. 50%
of Dim.A

SHAFT SEAL DESIGNS

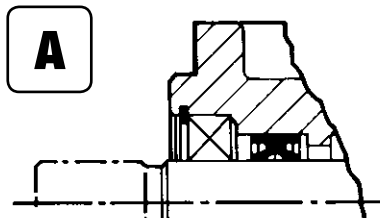

Suitable for drives with limited radial load

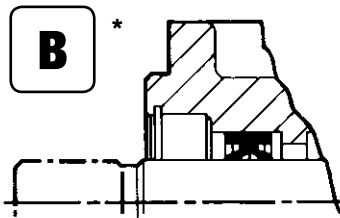

STANDARD
Suitable for drives with no radial or axial load

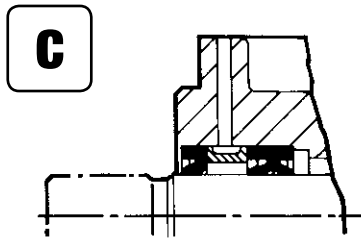

Suitable for drives with no radial or axial load where tell-tale external bleed is necessary

Z
HIGH PRESSURE
Shaft Seal is available with/without front bearing and bi-rotational check valves.

DRIVE - SHAFTS

Dimensions in millimetres

B *
22.2 Dia. SAE (7/8")
13 Tooth Involute Spline

INVOLUTE SPLINE DATA
Side Fit - Flat Root
Diametral Pitch 16/32
Pressure Angle 30°
Number of Teeth 13
Major Diameter;
21.79/21.69

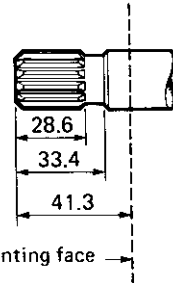

Standard flange mounting face

F *
22.2 Dia. SAE (7/8") Parallel Shaft
with 6.35mm Sq. Key

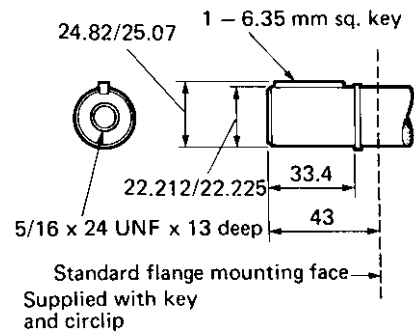

Standard flange mounting face
Supplied with key and circlip

* Preferred Feature

1600 INSTALLATION DATA

FLANGES

1

SAE Size 'A' 2 Hole with 6.4 pilot

Available for A, B & C designs

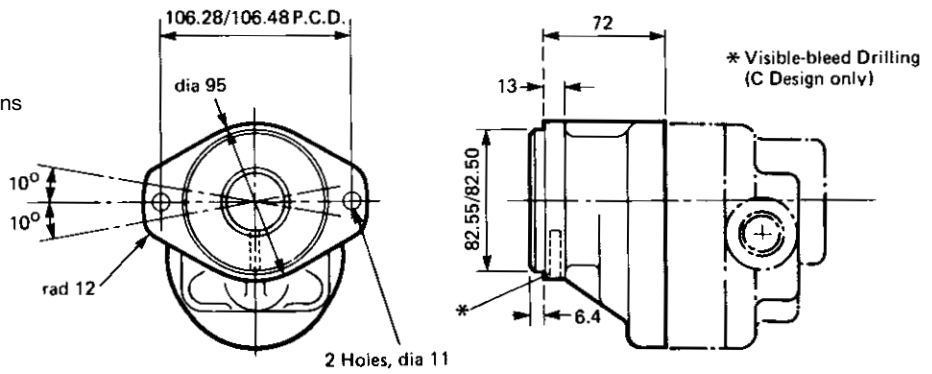

8

6 Hole Round Flange with 6.4 pilot

Available for A, B & C designs

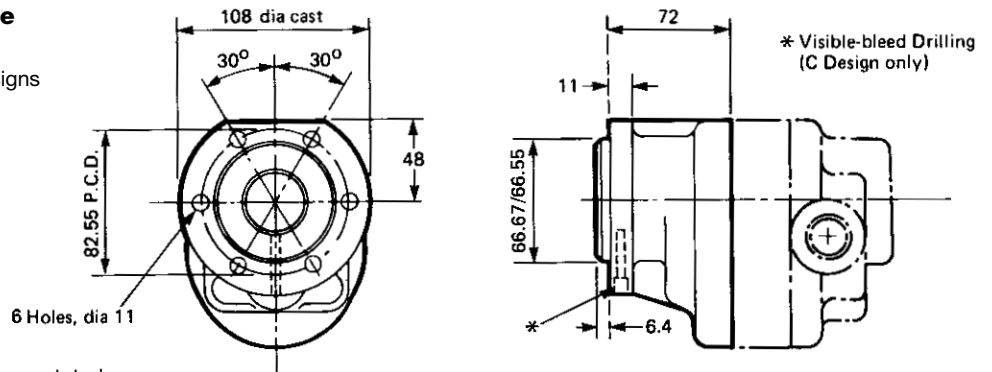

All dimensions are mm unless otherwise annotated

SIDE PORTS

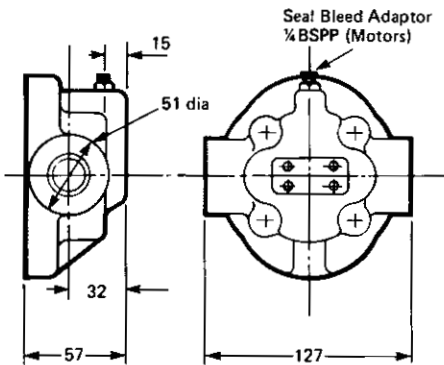

END PORTS

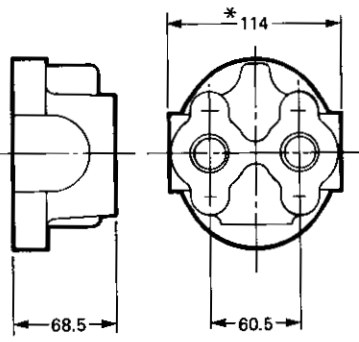

* For Units with Ground Drive, subtract 12.7 from this dimension

TOP PORTS

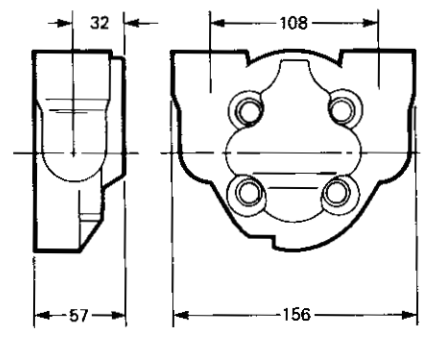

All dimensions are mm unless otherwise annotated

C5

* PORT SIZE
INLET } 1 in. B.S.P.P.
OUTLET }

E5

* PORT SIZE
INLET } 1 in. B.S.P.P.
OUTLET }

L32

PORT SIZE
INLET } 3/4 in. B.S.P.P.
OUTLET }

C9

PORT SIZE
INLET } 1 5/16 in. UNF - SAE
OUTLET } 1 5/16 '0' Ring

E9

PORT SIZE
INLET } 1 5/16 in. UNF - SAE
OUTLET } 1 5/16 '0' Ring

* Preferred Feature

1600 INSTALLATION DATA

INSTALLATION DIMENSIONS - MULTIPLE UNITS

Dimensions in millimetres

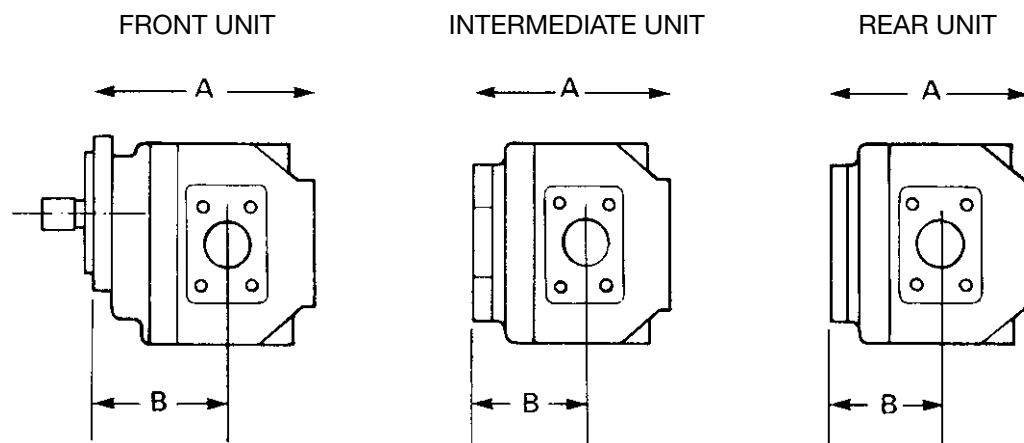

ALL SEAL DESIGNS												
2200				1900				1600				
SIZE	FRONT	INTER	REAR	SIZE	FRONT	INTER	REAR	SIZE	FRONT	INTER	REAR	
2208	A 178	167	159	1905	A 156	145	132	1604	A 145	145	145	
	B 108	97	97		B 94	83	83		B 113	113	113	
2210	A 178	167	159	1907	A 162	151	132	1606	A 145	145	145	
	B 108	97	97		B 97	86	83		B 113	113	113	
2213	A 184	173	165	1909	A 167	156	148	1608	A 149	149	149	
	B 116	105	105		B 97	86	86		B 118	118	118	
2215	A 194	193	185	1911	A 167	156	148	1610	A 154	154	154	
	B 116	115	115		B 102	90	90		B 122	122	122	
2216	A 194	193	185	1913	A 179	168	160	1613	A 162	162	162	
	B 116	115	115		B 102	90	90		B 130	130	130	
				1916	A 179	168	160	1617	A 172	172	172	
					B 102	90	90		B 140	140	140	

Note

- 1). When 1600 series is mounted to 1900 or 2200 series, its dimensions should be reduced by 14mm.
- 2). 1600 dimensions are for side-ported pumps/motors. For end ported units add 11mm to dimension A - rear units.

For dimensions not shown refer to the separate units section.

Total H.P./SPEED requirements must be within the limits given in the SHAFT LOADING CHARTS (see page 4).

Smallest capacity pump units are normally mounted in REAR position only.

In multiple MOTOR assemblies each unit is normally of the same size and capacity.

For Variations of Design, Performance and Specification see the relevant Selection Data Sheets for each unit.

1600 PERFORMANCE DATA

1604 PUMP

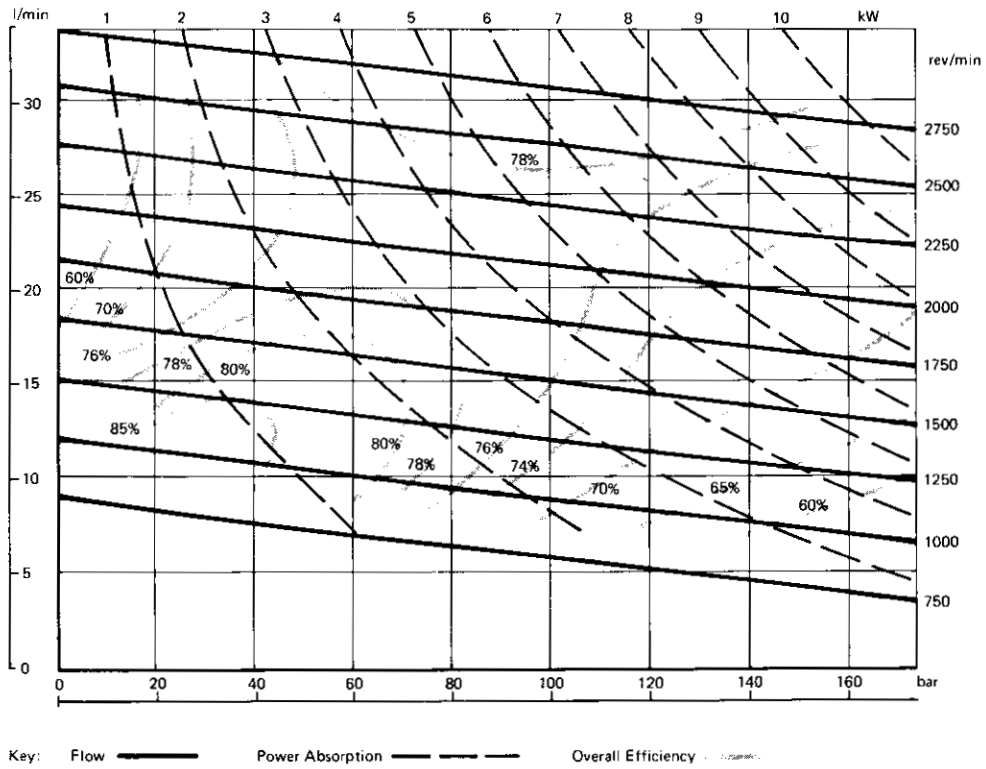

1600 PERFORMANCE DATA

1606 PUMP

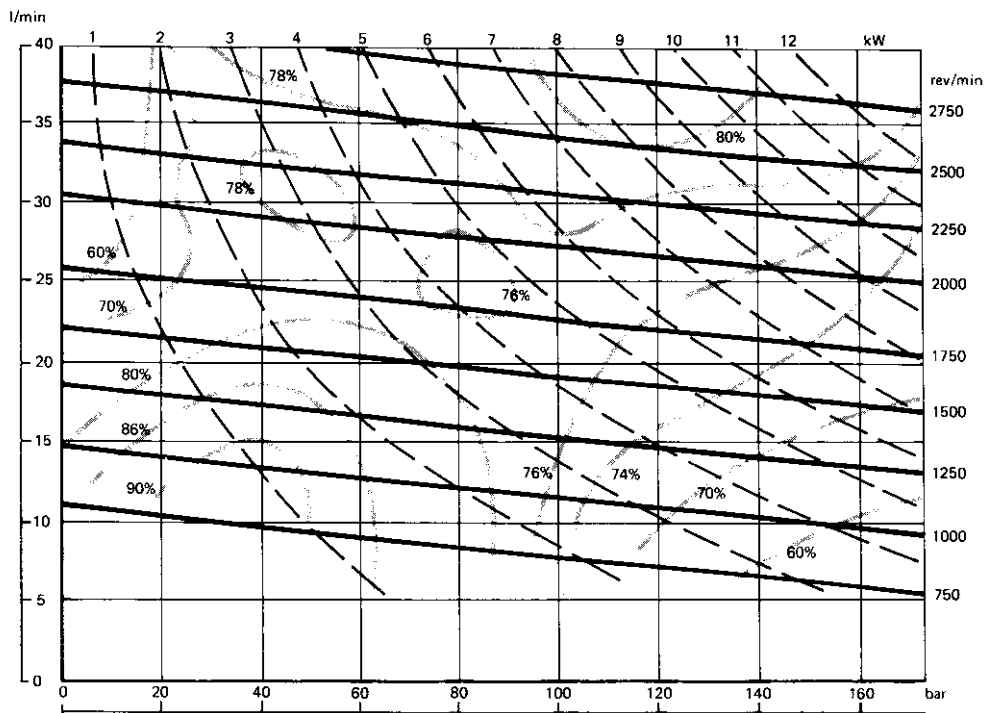

Key: Flow ——— Power Absorption - - - - Overall Efficiency ·····

1606 MOTOR

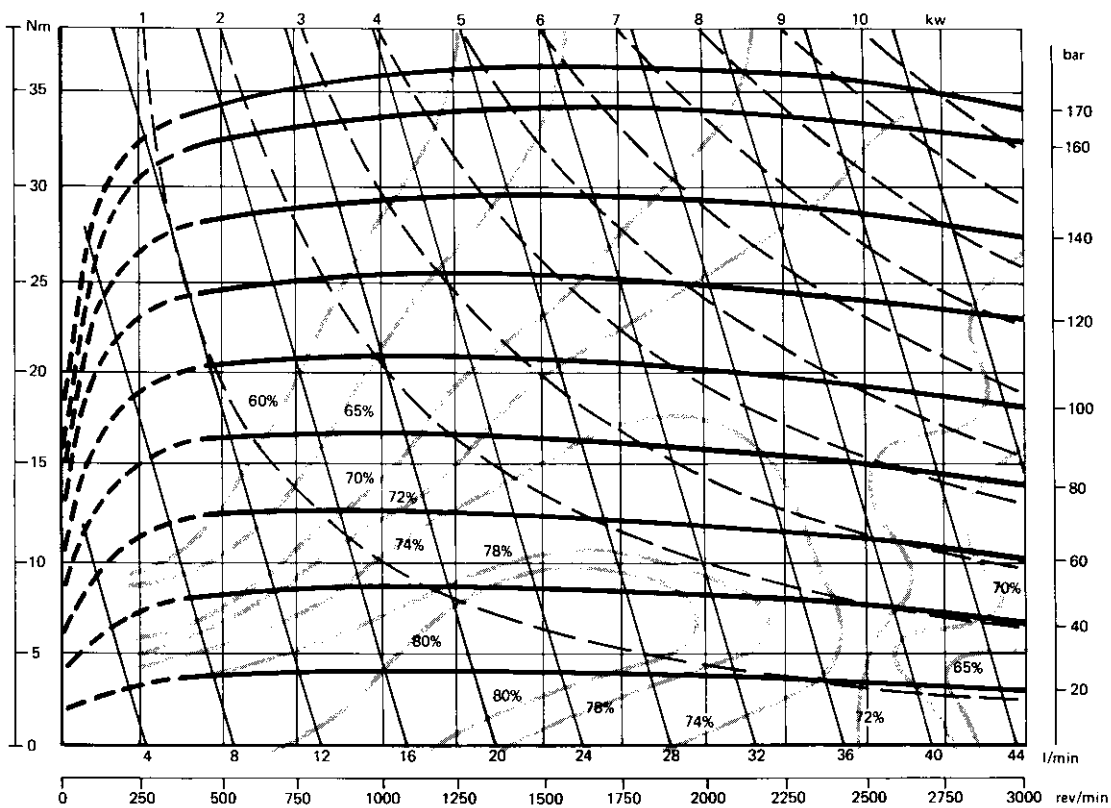

Key: Pressure ——— Power - - - - Flow ····· Overall Efficiency ·····

1600 PERFORMANCE DATA

1608 PUMP

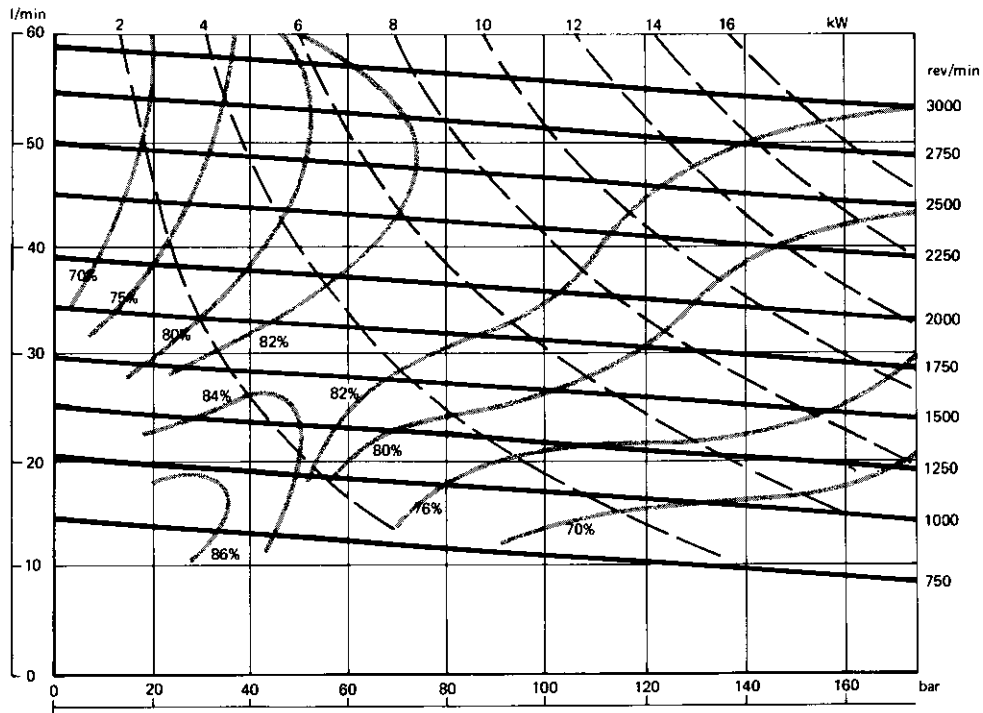

Key: Flow ——— Power Absorption - - - Overall Efficiency - . - .

1608 MOTOR

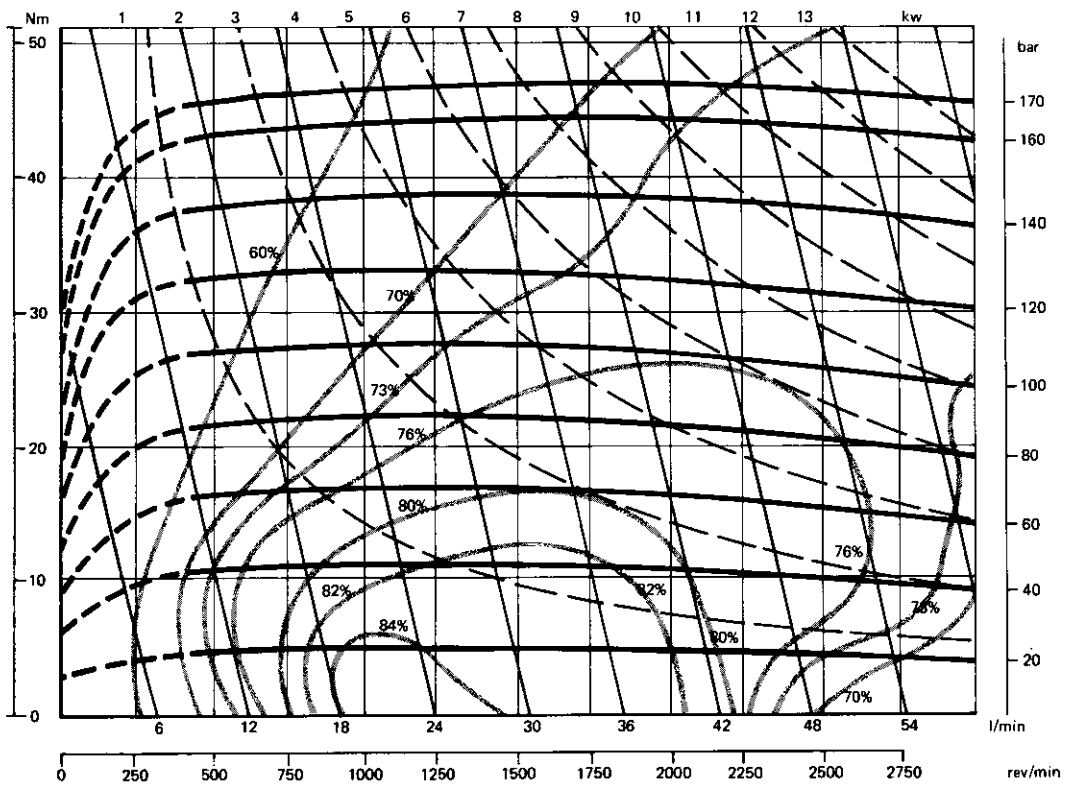

Key: Pressure ——— Power - - - Flow - . - . Overall Efficiency - . - .

1600 PERFORMANCE DATA

1610 PUMP

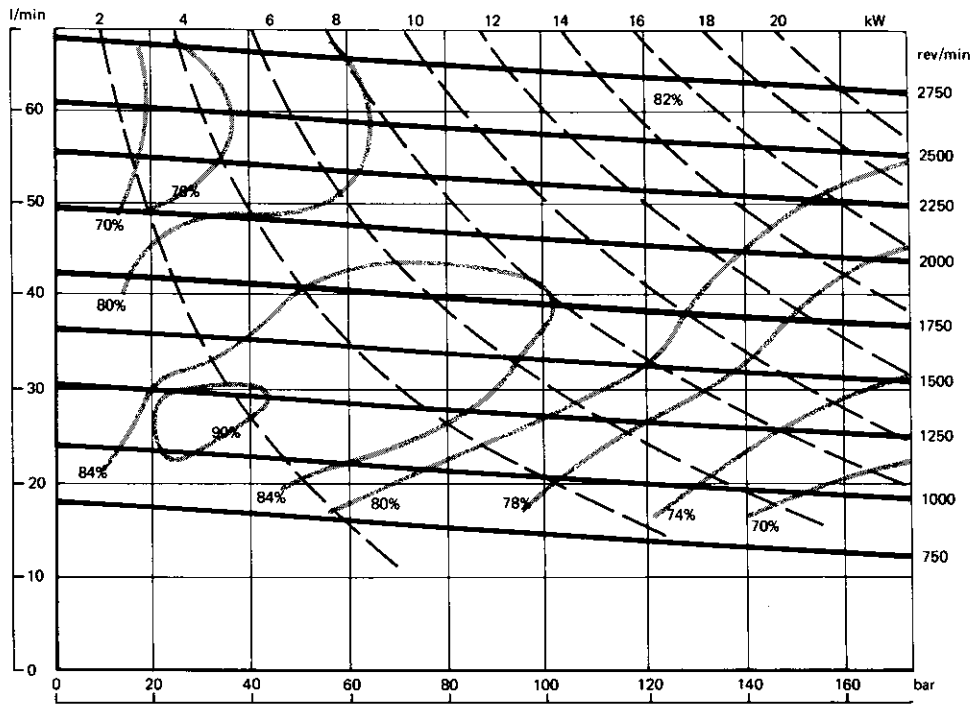

Key: Flow ——— Power Absorption - - - Overall Efficiency ·····

1610 MOTOR

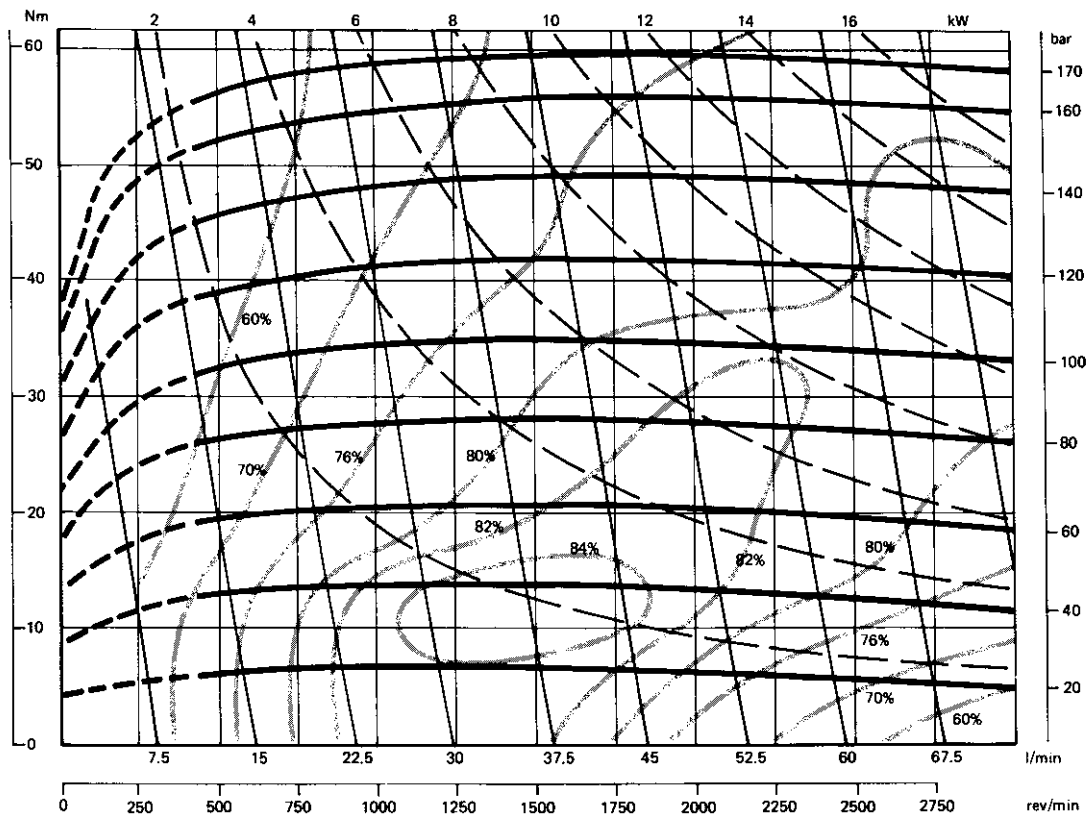

Key: Pressure ——— Power - - - Flow ····· Overall Efficiency ·····

1600 PERFORMANCE DATA

1613 PUMP

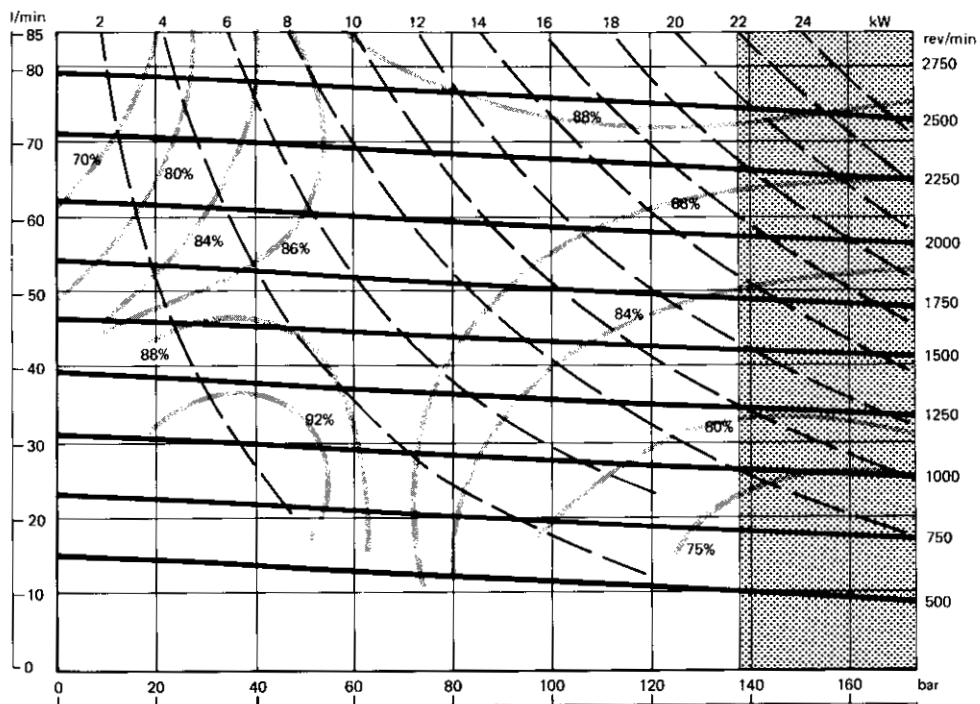

For operation within the shaded area refer to David Brown Hydraulics.

Key : Flow ——— Power Absorption - - - - Overall Efficiency

1613 MOTOR

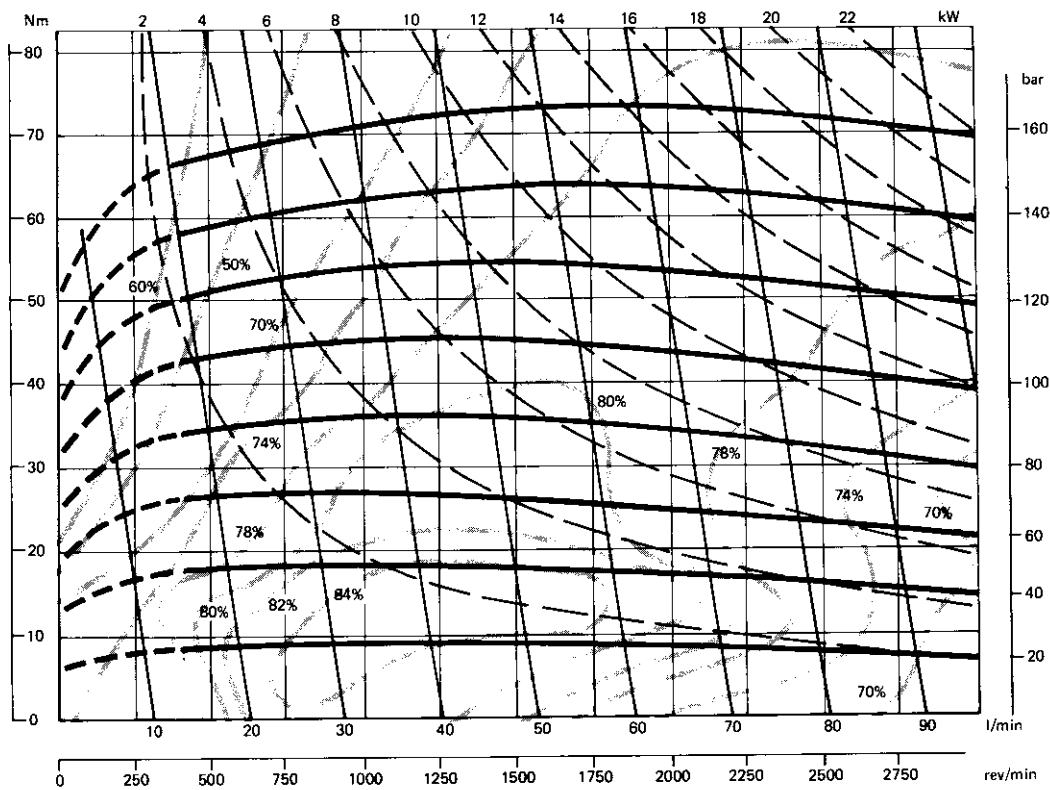

Key : Pressure ——— Power - - - - Flow Overall Efficiency

1600 PERFORMANCE DATA

1617 PUMP

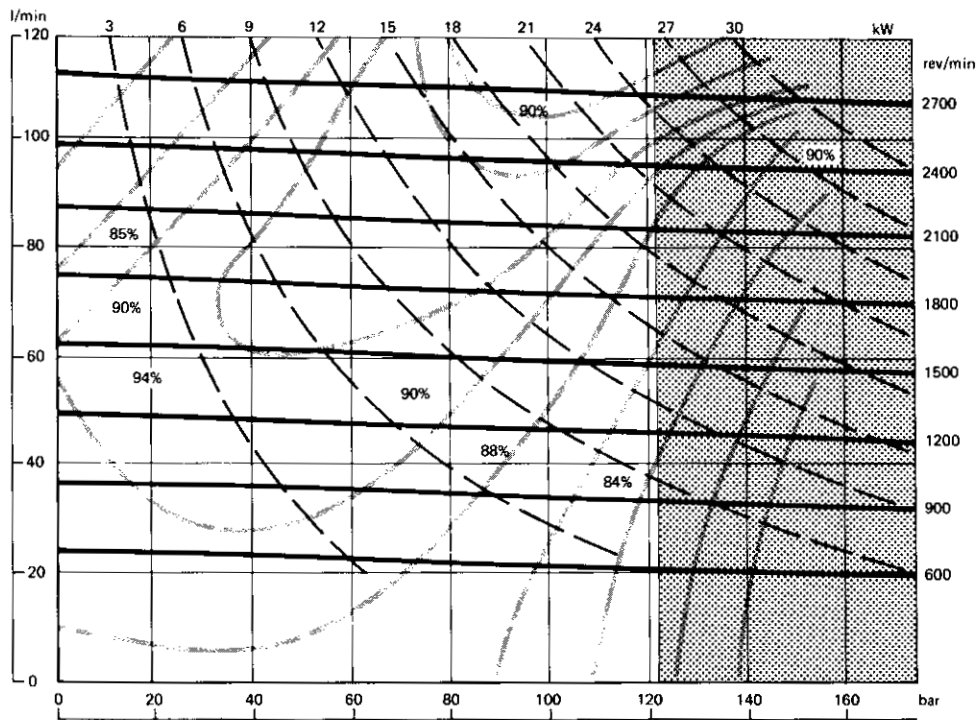

For operation within the shaded area refer to David Brown Hydraulics.

Key : Flow ——— Power Absorption - - - - Overall Efficiency ······

1617 MOTOR

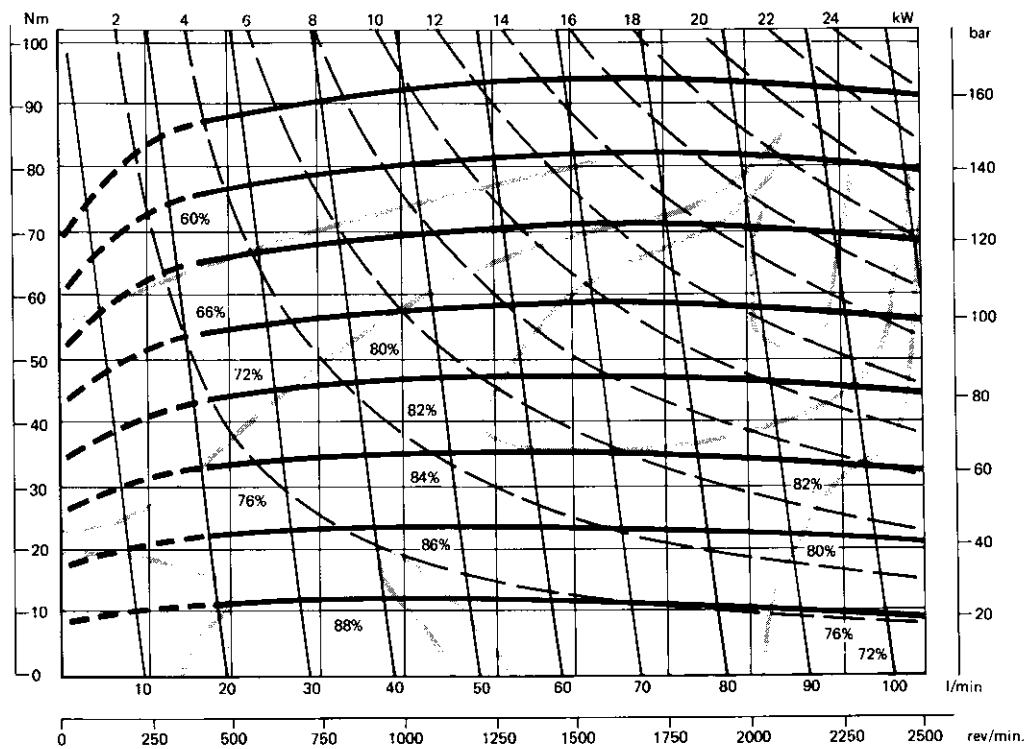

Key : Pressure ——— Power - - - - Flow ——— Overall Efficiency ······

1600 GENERAL DATA

THE CHART BELOW SHOWS THE DISPLACEMENT AND OPERATING PRESSURES AVAILABLE FROM THE 1600, 1900 AND 2200 RANGE OF GEAR PUMPS AND MOTORS.

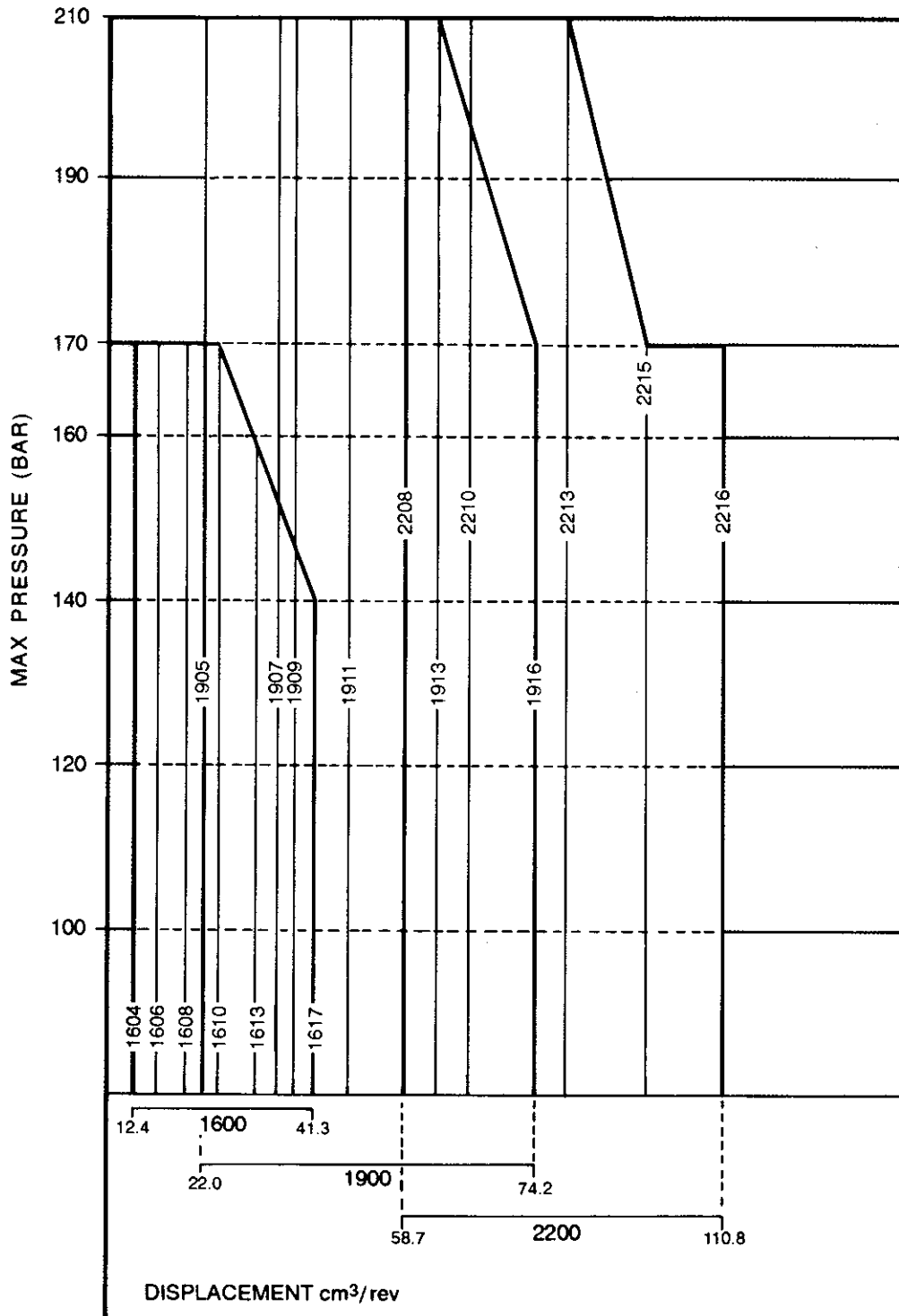

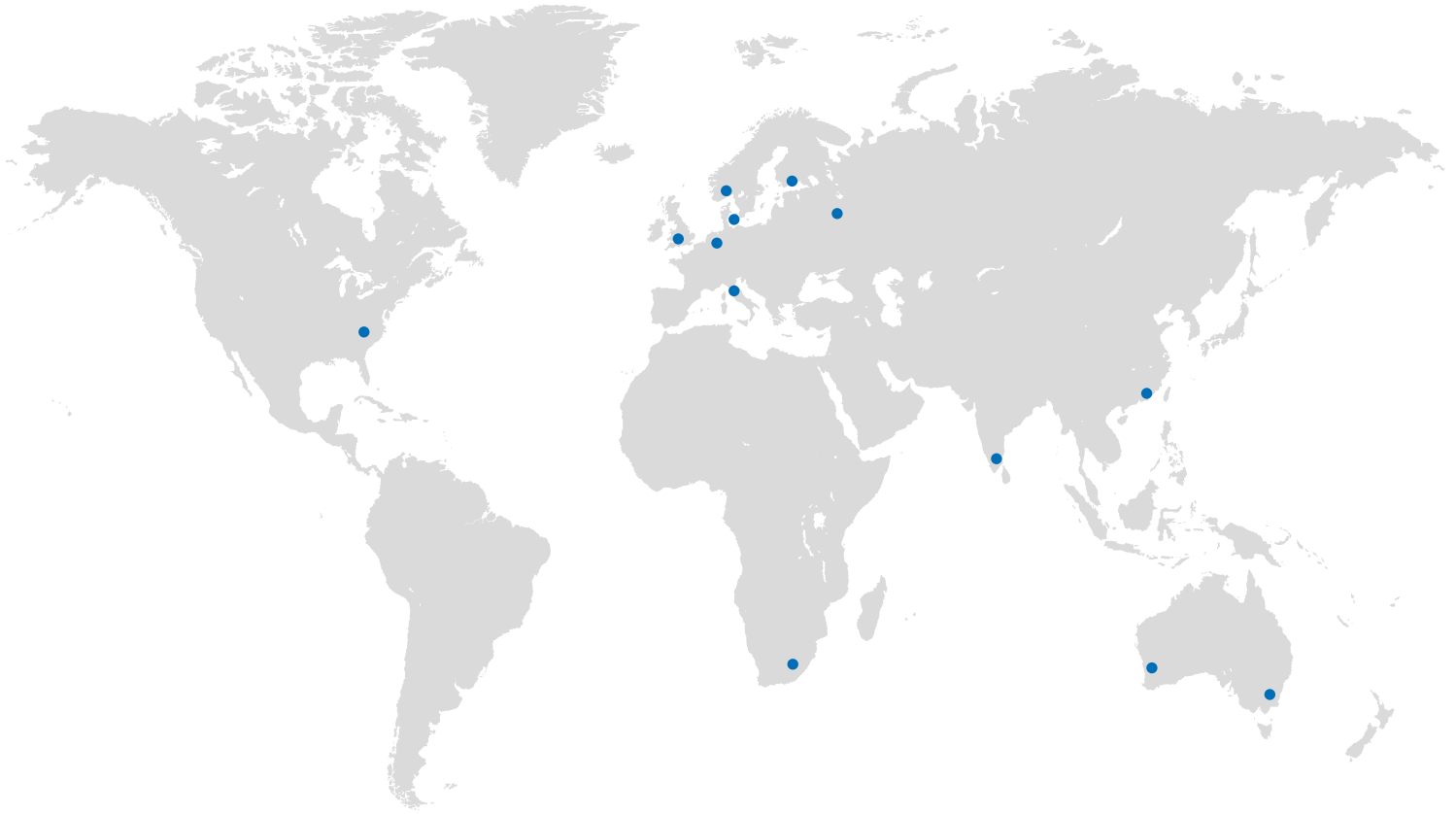

CONTACT INFORMATION

EMEA				
DENMARK	Hydreco Hydraulics Denmark A/S, Kastrup (Copenhagen)	Tel: +45 32 51 40 15	Fax: +45 32 51 20 22	info-dk@hydreco.com
FINLAND	Hydreco Hydraulics Finland Oy, Helsinki	Tel: +358 9 342 4120	Fax: +358 9 342 41236	sales-fi@hydreco.com
GERMANY	Hydreco Hydraulics GmbH, Straelen (NRW)	Tel: +49 2834 94303-41	Fax: +49 2834 94303-64	info-de@hydreco.com
ITALY	Hydreco Hydraulics Italia Srl, Vignola (MO)	Tel: +39 059-7700411	Fax: +39 059-7700425	sales-it@hydreco.com
NORWAY	Hydreco Hydraulics Norway AS, Skjetten	Tel: +47 22 90 94 10	Fax: -	post-no@hydreco.com
RUSSIA	Hydreco Hydraulics Russia, Moscow	Tel: +7 495 967 3453	Fax: +7 495 785 0636	sales-ru@hydreco.com
SOUTH AFRICA	Hydreco Hydraulics (Proprietary) Ltd, Benoni	Tel: +27(0)11 748 0076	Fax: +27 (0) 86 558 2942	sales-sa@hydreco.com
UK	Hydreco Hydraulics Ltd, Poole, Dorset	Tel: +44 (0) 1202 627500	Fax: +44 (0) 1202 627555	info-uk@hydreco.com
AMERICAS				
USA	Hydreco Inc, Charlotte (NC)	Tel: +1 704 295-7575	Fax: +1 704 295-7574	sales-us@hydreco.com
LATIN AMERICA		Tel: +1 704 572-6266		sales-es@hydreco.com
APAC				
AUSTRALIA	Hydreco Hydraulics Pty Ltd, Seven Hills (NSW)	Tel: +61 2 9838 6800	Fax: +61 2 9838 6899	sales-au@hydreco.com
AUSTRALIA	Hydreco Hydraulics Pty Ltd, Narellan (NSW)	Tel: +61 246 476 577	Fax: -	sales-au@hydreco.com
AUSTRALIA	Hydreco Hoist & Winch Sales (WA) Pty Ltd, Bassendean (WA)	Tel: +61 8 9377 2211	Fax: +61 8 9377 2223	sales-au@hydreco.com
CHINA	Hydreco Hydraulics (Xiamen) Co. Ltd, Xiamen, (Fujian)	Tel: +86 0592 2237 901	Fax: +86 0592 2237 052	sales-cn@hydreco.com
INDIA	Hydreco Hydraulics India Private Ltd, Bangalore	Tel: +91 80 42713100	Fax: +91 80 42713111	sales-in@hydreco.com