

4

HIGH TORQUE, HIGH SPEED
RADIAL PISTON HYDRAULIC MOTORS

GM SERIES

TECHNICAL CATALOGUE

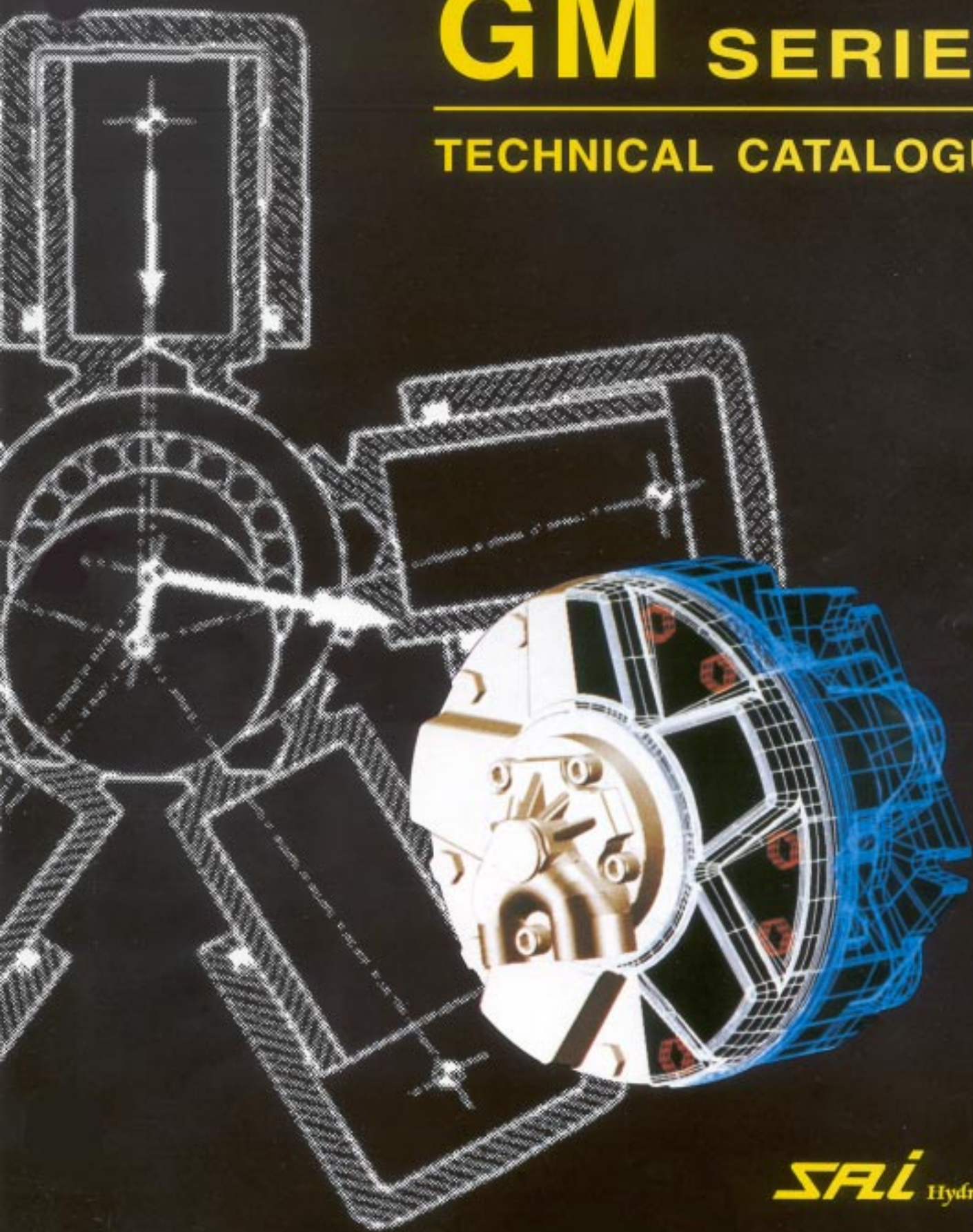

SRI Hydraulics

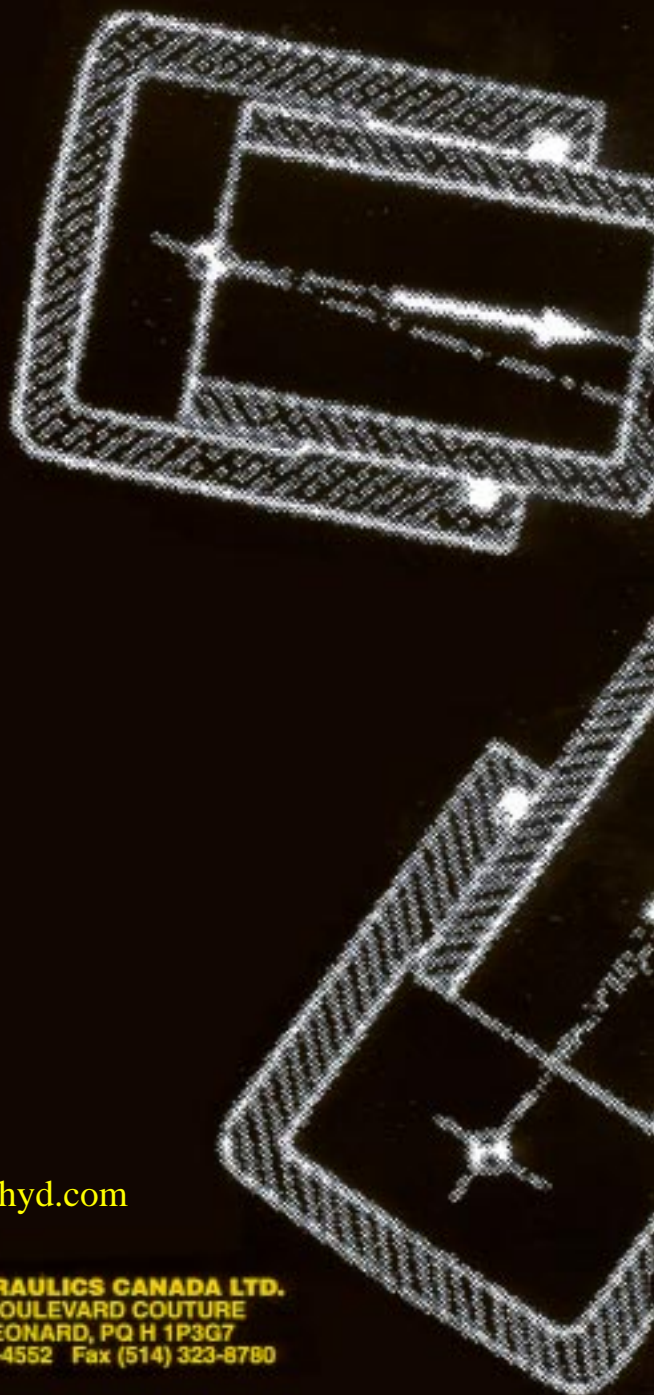

SAI Hydraulics, Inc.
3905 W. 9th STREET
TRAINER, PA 19061
(610) 497-0190 Fax (610) 497-0194

www.saihyd.com

info@saihyd.com

SAI HYDRAULICS CANADA LTD.
6105 BOULEVARD COUTURE
ST. LEONARD, PQ H 1P3G7
(514) 323-4552 Fax (514) 323-8780

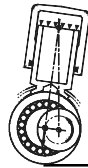

*Crankshaft Design
Radial Piston Hydraulic Motors*

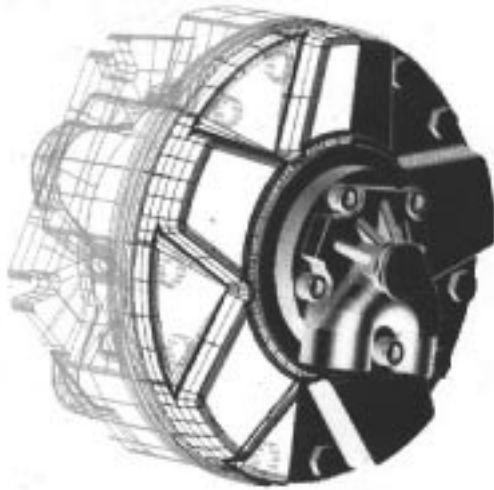

GM SERIES

TECHNICAL CATALOG

<u>CONTENTS</u>	<u>PAGE</u>
Motor Displacement Table	2
Motor Characteristics & Technical Data	3
GM05 Series	9
GM1 Series	13
GM2 Series	17
GM3/GM3A Series	21
GM4 Series	25
GM5A Series	29
GM6 Series	33
L7 Series	37
<u>MOTOR - GEARBOX COMBINATION</u>	
GR Series	41
<u>DISTRIBUTORS & SAE FLANGES</u>	
Distributor Valves	46
SAE Flanges	52

Motor Displacement Table

	GM05 See Page 9	60	75	110	130	150	170	200			
	Displacement <i>in³/rev</i>	3.59	4.51	7.04	7.87	9.20	10.14	11.64			
	Peak pressure <i>psi</i>	6400	6000	5700	5500	5500	5000	5000			
	Max. speed <i>rpm</i>	1200	1200	1000	1000	1000	900	800			
	Peak power <i>HP</i>	50	50	50	50	50	50	50			
	GM1 See Page 13	100	150	175	200	250	300	320*			
	Displacement <i>in³/rev</i>	6.04	9.40	10.50	12.27	14.83	17.70	19.16			
	Peak pressure <i>psi</i>	6400	6000	5700	5500	5500	5000	5000			
	Max. speed <i>rpm</i>	1200	1200	1200	1200	1000	900	900			
	Peak power <i>HP</i>	75	75	75	75	75	75	75			
	GM2 See Page 17	200	250	300	350	420	500	600			
	Displacement <i>in³/rev</i>	11.72	15.32	18.55	21.18	25.94	30.08	34.47			
	Peak pressure <i>psi</i>	6400	6000	5700	5700	5500	5500	5000			
	Max. speed <i>rpm</i>	1000	1000	900	900	850	850	800			
	Peak power <i>HP</i>	95	95	95	95	95	95	95			
	GM3 See Page 21	350	425	500	600	700	800	900	1000		
	Displacement <i>in³/rev</i>	21.48	26.00	29.66	36.31	42.12	48.33	53.27	60.23		
	Peak pressure <i>psi</i>	6400	6000	6000	5700	5500	5500	5000	5000		
	Max. speed <i>rpm</i>	800	750	700	675	625	600	550	500		
	Peak power <i>HP</i>	120	120	120	120	120	120	120	120		
	GM3A See Page 21	350	425	500	600	700	800				
	Displacement <i>in³/rev</i>	21.48	26.00	29.66	36.31	42.12	48.33				
	Peak pressure <i>psi</i>	6400	6000	6000	5700	5500	5500				
	Max. speed <i>rpm</i>	800	750	700	675	625	600				
	Peak power <i>HP</i>	120	120	120	120	120	120				
	GM4 See Page 25	400	500	600	800	900	1000	1100	1250*	1300*	
	Displacement <i>in³/rev</i>	24.53	30.70	37.59	48.39	55.17	62.37	68.10	76.10	80.31	
	Peak pressure <i>psi</i>	6400	6400	6000	5700	5700	5500	5500	5000	5000	
	Max. speed <i>rpm</i>	700	650	625	550	500	450	425	400	375	
	Peak power <i>HP</i>	150	150	150	150	150	150	150	150	150	
	GM5A See Page 29	525	650	800	1000	1200	1300	1450	1600	1800	2000
	Displacement <i>in³/rev</i>	32.10	40.21	49.25	63.40	72.31	81.77	89.22	99.71	110.8	122.5
	Peak pressure <i>psi</i>	6400	6400	6000	6000	5700	5700	5500	5500	5000	5000
	Max. speed <i>rpm</i>	700	650	625	550	500	450	425	400	375	375
	Peak power <i>HP</i>	190	190	190	190	190	190	190	190	190	190
	GM6 See Page 33	1700	2100	2500	3000						
	Displacement <i>in³/rev</i>	103.10	129.80	153.40	185.60						
	Peak pressure <i>psi</i>	6400	5700	5500	5000						
	Max. speed <i>rpm</i>	400	350	300	250						
	Peak power <i>HP</i>	270	270	270	270						
	L7 See Page 37	2000	2500	3000	3600	4300					
	Displacement <i>in³/rev</i>	125.27	154.17	183.06	221.90	263.61					
	Peak pressure <i>psi</i>	6000	6000	6000	6000	6000					
	Max. speed <i>rpm</i>	280	260	220	200	170					
	Peak power <i>HP</i>	147	174	202	255	295					

* See motor technical pages

Crankshaft Design Radial Piston Motors

The main characteristics of this type of design are high mechanical efficiency, especially at start up, and high volumetric efficiency.

A number of features distinguish SAI Motors from other radial piston designs:

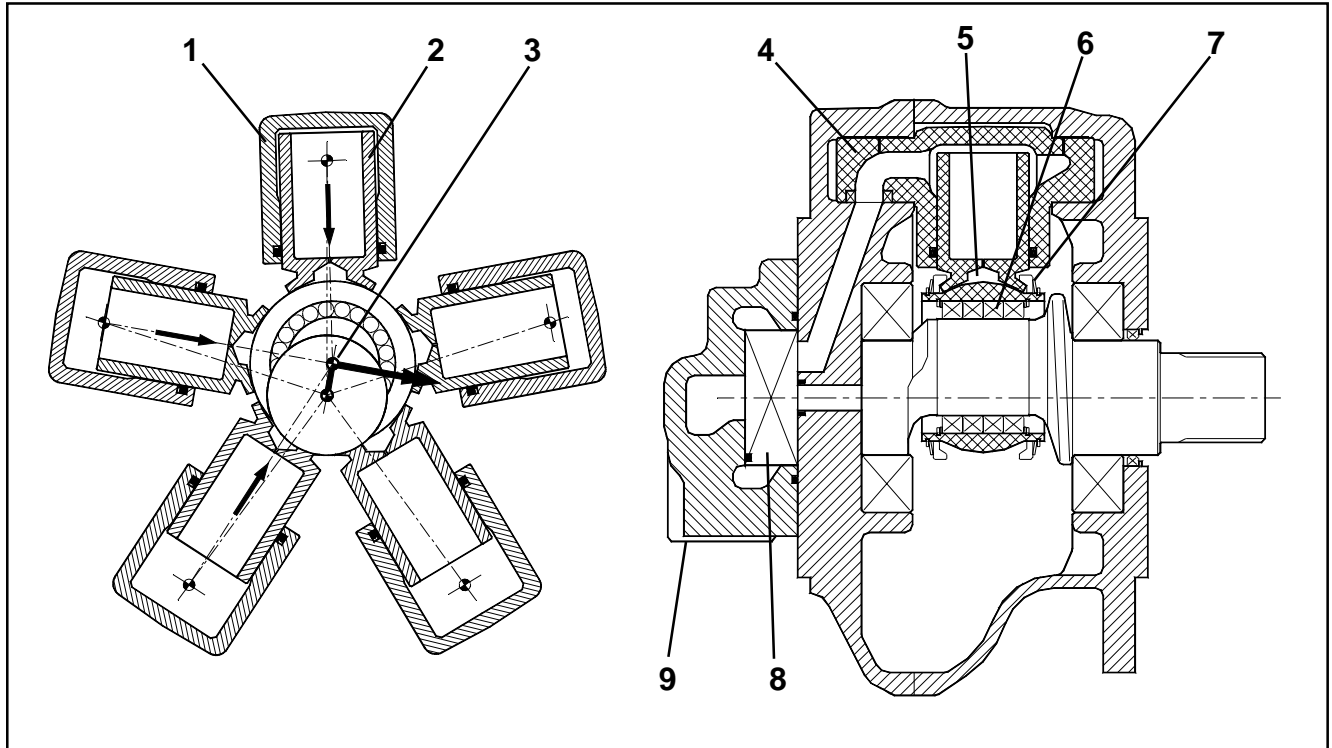

Pivoting cylinder: the cylinder (1) remaining aligned with the eccentric of the crank (3), eliminates side loading between the cylinder and piston (2). The articulation of the cylinder-piston assembly is achieved with large diameter trunnions (4) ensuring low specific loads.

Double piston support bearing: the pistons transmit their load to the shaft via a hydrostatic bearing (5) and a central roller bearing (6). The roller bearing eliminates the sliding velocity between the piston foot and the spherical piston support ring, reducing heat, friction, wearing and improving starting torque, low speed operation (reduced stick slip) and high speed operation. The hydrostatic bearing reduces metal-metal contact ensuring optimal lubrication and low friction.

Piston retaining rings (7) ensure the piston remains in contact with the shaft in all operating conditions, even during cavitation.

Rotary axial distributor (8) ensures optimal distribution with short, large section ducts for reduced power-loss with high flows, and very high volumetric efficiency; extensive clearance recovery capability of the seals ensures optimal functionality throughout the motor lifetime and in conditions of thermal shock.

Interchangeable motor (9): a wide range of distributors are available with various pressure and flow control valves.

GM Series Characteristics

GM Series Motors are a result of the many years of experience gained with the preceding M, L and P Series Motors, and incorporate a number of design variations with respect to these series to increase the strength of the motor casings and the load capacity of the internal dynamic components. The result is a series of motors with high continuous power ratings, reduced internal loads and high mechanical and volumetric efficiency that contribute in reducing the amount of heat and therefore also the negative effects associated with it.

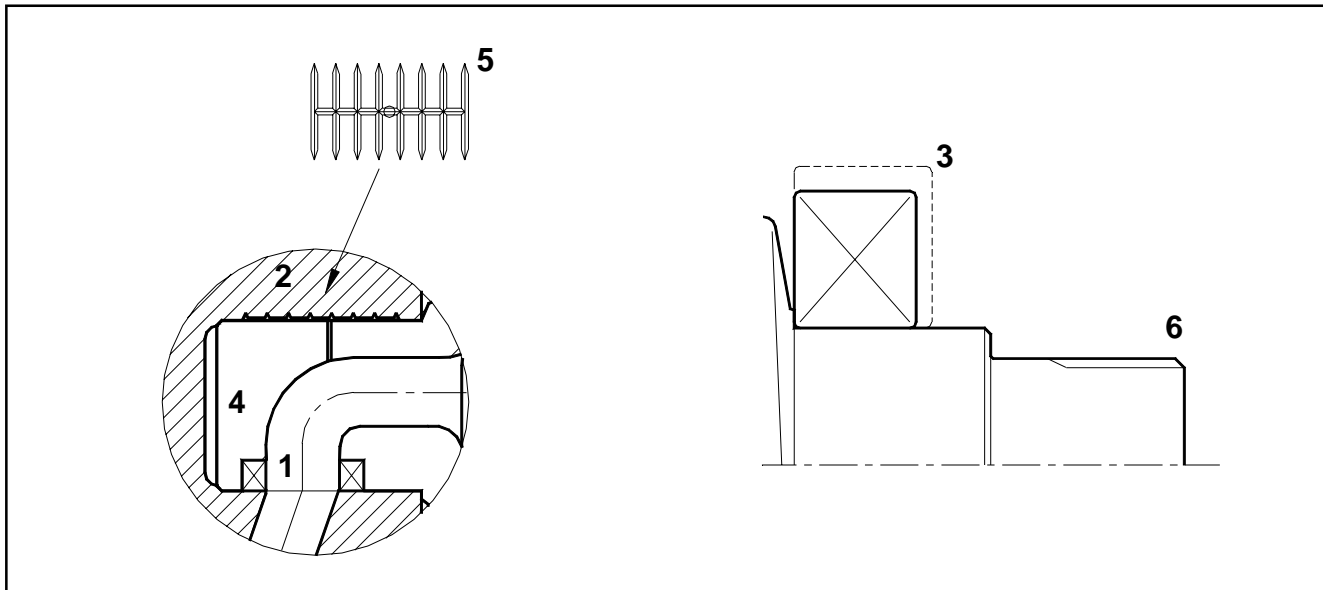

- **Radial injection cylinder feed (1)** eliminates direct hydraulic axial loading of the motor casing.
- **Larger cylinder feed channels (1)** for reduced power loss with high flows.
- **Stronger castings (2)** and internal reinforcement ribbing: increased casing strength and stiffness for higher internal and external load capacity.
- **High load capacity bearings (3)** for applications requiring high lifetime, high power/pressure, high external loads.
- **Larger cylinder trunnions (4)** for increased strength and stiffness and reduced specific loads.
- **Cylinder trunnions with hydraulic balancing (5)** to reduce friction, wearing and heat generation, enabling operation with higher powers and improved efficiency.
- **Compatibility with shafts (6)**, adaptors, flanges, distributors of the motors of the preceding series.
- **Reduced number of components** for a more simple and reliable design.
- **Compatibility with non-polluting oils.**

PRESSURE RATINGS

All the motors are rated at a nominal continuous pressure rating of 3,650 psi. The continuous and average operating pressure, however, should be chosen in function of the required bearing lifetime (see bearing lifetime graphs).

The peak operating pressures are given in the relative displacement tables. The motors may work at peak pressures for periods not exceeding 1% per minute, no more than 10 times per hour.

BACK-PRESSURE

The motors are capable of operating with high back-pressures with high efficiency, e.g. for series circuit applications.

The allowable pressures vary in function piston diameter and other factors. If the motors are required for an application with back pressure contact the technical department for further details.

Typical allowable back-pressure

	Port A	Port B
Cont.	3,000 psi	2,200 psi
Peak	5,000 psi	5,000 psi

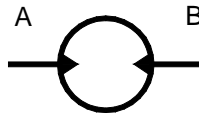

CASE PRESSURE

Continuous case pressure: 15 psi

Peak case pressure: 75 psi

The case pressure is independent of the return line pressure.

For higher pressures (up to 350 psi) contact the technical department.

TORQUE

To obtain the theoretical output torque of a motor, multiply the specific torque (lb.ft/psi) given in the displacement tables by the pressure (psi).

The graph below shows the output torque variation as the shaft rotates through 360°.

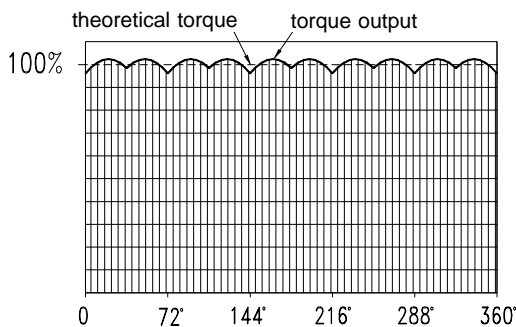

STARTING TORQUE

Typical starting torque efficiencies are given in the performance graphs of the motors. The starting torque, however, also depends on the starting position of the shaft (see graph above).

LOW SPEED OPERATION

The motors are capable of operating at low speeds with a high degree of speed stability. The minimum stable speed depends on the displacement of the motor. In general the motors remain sensitive to flows of 6 in³/min + motor leakage rate. Best results are obtained with 75-150 psi back-pressure and after the circuit has been completely purged of air by running it at 2/3 max speed for 5-10 mins.

The output torque does not fall off at very low speeds or at standstill.

2-SPEED OPERATION

For applications containing at least two drive units that require 2-speed operation, SAI can supply the flow control valves for a series-parallel circuit with speed differential also in series mode.

The valves enable dynamic switching of the circuit from series to parallel configuration to obtain the high-torque/low-speed or high-speed/low-torque operating modes. A pressure reducing valve minimizes the differential effect of motors operating in series or parallel circuits.

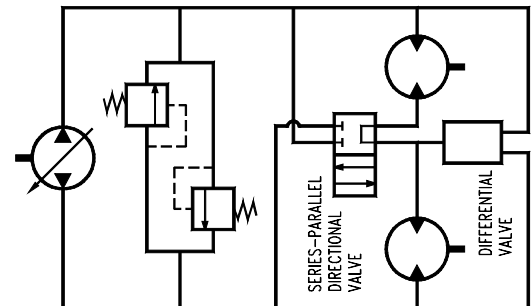

NOISE LEVELS

The motors operate at lowest noise levels with a back-pressure of 75-150 psi, such as in closed circuits. Pressure lines and motor support structures can be efficient noise propagators or amplifiers. Pressure lines should preferably be made up of straight rigid lengths, flexible corners, firmly fixed to rigid supports at irregular intervals away from sheet panelling. Motors must be rigidly fixed to solid supports.

SILENT MOTORS

Motors can be supplied with special distributor that run nearly silently in a wide operating range.

Please contact technical department for further details.

VIBRATION

The motors can be supplied with a counterbalanced shaft to reduce vibrations at high speeds.

Please contact technical department for further details.

CAVITATION

The design of the motors ensures they are not damaged if subjected to cavitation, even for prolonged periods of time.

The motors will rotate normally even with empty cylinders (i.e. no oil - air, or vacuum), which is useful for disconnecting the motor from the hydraulic circuit (see below).

OPERATION IN FREEWHEELING AND AS HYDRAULIC BRAKE

Transitions from normal motor operating mode to free-wheeling and hydraulic braking mode can be carried out dynamically.

DISCONNECTION FROM HYDRAULIC CIRCUIT

The motors can be disconnected from the hydraulic and driven externally (freewheeling, free fall, in case of breakdown, etc.) at speeds of up to the max. speeds given. For higher speeds please contact our technical office.

The diagram below show four possible circuit configurations for motor disconnection and/or for operation in free-wheeling:

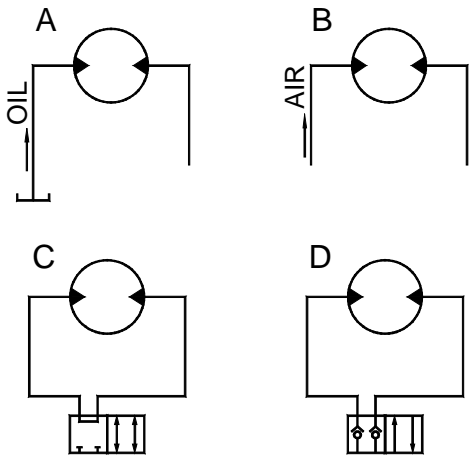

A: It is possible that the motor runs with only partially filled cylinders, causing a significant increase in noise levels. This type of circuit is to be avoided for high speed applications;

B: The motor runs with air in the cylinders. This type is ideal for high speed freewheeling applications;

C: The motor runs with inlet and outlet ports connected. This type of circuit is suitable for applications in which it is necessary to control the speed of the motor (e.g., with variable throttle);

D: The motors run with air in the cylinders subjected to negative pressure. The motors can operate in these conditions for several hours without being damaged or overheating and absorb very little torque.

HYDRAULIC FLUIDS

MINERAL OILS

SAI recommend the use of high quality mineral-based hydraulic oil, containing anti-wear, anti-foaming, anti-oxidation and extreme pressure additives.

Oil temperature: ideal +86°F to +122°F
allowable -68°F to +176°F

On request, motors can be supplied to operate with lower (to -104°F) or higher (to +248°F) temperatures.

Oil viscosity: ideal 40 to 60 cSt
allowable 5 to 3000 cSt

The choice of oil should be made so that the viscosity of the oil lies within the given range at its normal operating temperature.

ALTERNATIVE FLUIDS

- Synthetic fluids:

(Phosphate esters, polyesters, ...)

These fluids have similar properties to mineral oils and the same pressure, speed, temperature and viscosity ratings apply.

These fluids may require seals made of a different material (e.g. Viton), which are available on request.

- Water-based fluids:

(Water-oil emulsions, water-glycol solutions, ...) with these fluids the following limits apply:

max. continuous pressure	1,450 psi
max. speed reduction	50%
allowable temperature	+50 to +140°F

- Vegetable oils

The characteristics of these oils vary widely and manufacturers' recommendations should be followed. In general, while lubricating qualities are similar to those of mineral oils, temperature limits may apply and the oil may need to be changed frequently.

The warranty on motors operating with fluids other than mineral oils for high pressure hydraulic applications is only valid if the application is first approved by SAI.

FILTRATION

SAI recommend filters of 25 mm or better.

Recommended oil contamination class:

ISO/DIS 4406	- class 18/12
CETOP RP 70 H	- class 18/12
BS 5540/4	- class 18/12
SAE 749	- class 5
NAS 1638	- class 8

BRONZE COMPONENTS

GM-series motors do not contain bronze components. However, high speed distributors (including the standard D40 and D90 distributors) do contain bronze components. If the hydraulic fluid used is not compatible with bronze, select an optional low speed (LS) distributor (no bronze components) or contact our technical department.

NON MAGNETIC MOTORS

On request, it is possible to supply motors with up to 70% non magnetic content.

DIRECTION OF SHAFT ROTATION (Fig. 1)

All motors are bi-directional. The direction of shaft rotation is determined by the direction of oil flow. Standard motors are supplied so that flow entering in Port A causes the shaft to rotate clockwise (as seen from the shaft side of the motor). Flow entering Port B causes anticlockwise rotation. Motors can be supplied with the reverse configuration: see motor order codes.

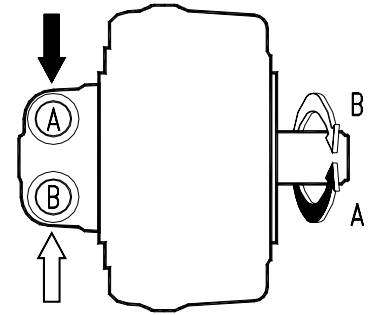

Fig.1 Direction of shaft rotation

DRAIN-LINE POSITIONING (Fig. 2)

The drain-line must be positioned in such a way that there is always sufficient oil in the casing for the lubrication of the dynamic components in the motor. If the motor is installed with the shaft in a horizontal position, the drain-line should be connected to the uppermost drain-line port. If the motor is installed with the shaft pointing downwards the drain-line can be connected to either of the two drain-line ports. If the motor is installed with the shaft pointing upwards, the motor casing has to be entirely filled with oil before being installed and the drain-line connected in such a way that no air can enter into the motor casing so causing the front bearing to run dry. This is especially important if the motor operates at very low speeds or remains inactive for long periods. For alternative systems, contact your SAI representative. The drain-line should be of a diameter corresponding to the size of the drain line port and flow must not be obstructed by sharp corners, restrictions, etc. Standard motors are supplied with drain port Y (Fig. 3) closed (zinc plated HH plug) and drain port X open (with plastic plug). Motors can be supplied with Y-open, X-closed: see motor order codes.

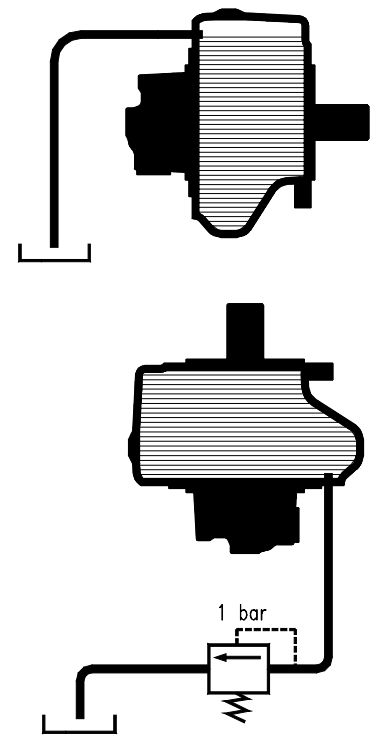

Fig.2 Drain line positioning

DISTRIBUTOR COVER ORIENTATION (Fig. 3)

Motors may be supplied with the distributor assembled with the arrow pointing towards any one of the five pistons. To order, use assembly code DM1, DM2, DM3, etc. (DM1 = standard)

START-UP

Before connecting any tubes ensure that they are thoroughly cleaned, any excess material that could work loose should be removed and there should not be any oxidation of surfaces that come into contact with the oil.

Before starting work the motor casing must be filled with oil.

Before starting work the hydraulic circuit should be purged of air. This can be achieved by running the motor without load for 10-20 minutes, during which time checks should be made for leakages from connections.

During the first few hours of working under load checks should be made for leakages from connections and to ensure that all components remain firmly fixed to their supports.

All motors are factory tested and do not require to be run in.

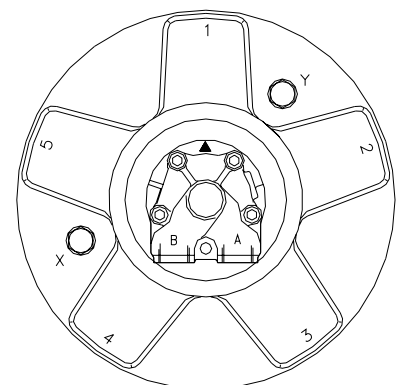

Fig.3 Distributor cover orientation

MOTOR BEARING LIFETIME

The bearing lifetimes given in this catalogue are B10 lifetimes. The B10 lifetime is the period of work after which 10% of the bearings can be expected to show signs of wearing. The average lifetime of the bearing, the B50 lifetime (where 50% of the bearings show signs of wearing), is approximately 5 times the B10 value.

The continuous operating pressures of any motor should be chosen in function of the required motor lifetime.

CALCULATION OF BEARING LIFETIME

The lifetime of the bearings may be calculated using the graphs given for each motor series.

How to use the graphs:

On the left side of the graph, find the intersection between the vertical line of the motor displacement (1) and the curved line indicating the average working pressure (2). From intersection, trace a horizontal line (3) across to the right side of the graph. Trace a vertical line (4) from the speed scale intersecting the horizontal line (3). Read off the bearing lifetime from the lifetime isoclines.

MOTOR LIFETIME REQUIREMENT

The required bearing lifetime may be calculated using the following formula:

$$\text{Life (hours)} = \text{Hours of work per day} \times \text{Days work per year} \times \text{No. of years} \times \text{Correction factor}$$

Correction factor: The calculated lifetime of the bearings presumes favorable lubrication conditions with oil having values of temperature, viscosity and oil cleanliness that lie within the given ranges.

A correction factor should be applied for applications, for example including continuous duty over several hours, where high oil temperatures or other anomalous working conditions can occur.

The table below indicates the correction factor to be applied in function of the duration of the cycle of continuous work, for applications in which the working conditions of the oil are not regularly checked.

Non-Stop

Work Cycle (hrs)	<3	6	12	18	24
Correction Factor	1	1.25	1.5	2	3

If the bearing lifetime for a desired working pressure is insufficient please contact the technical department.

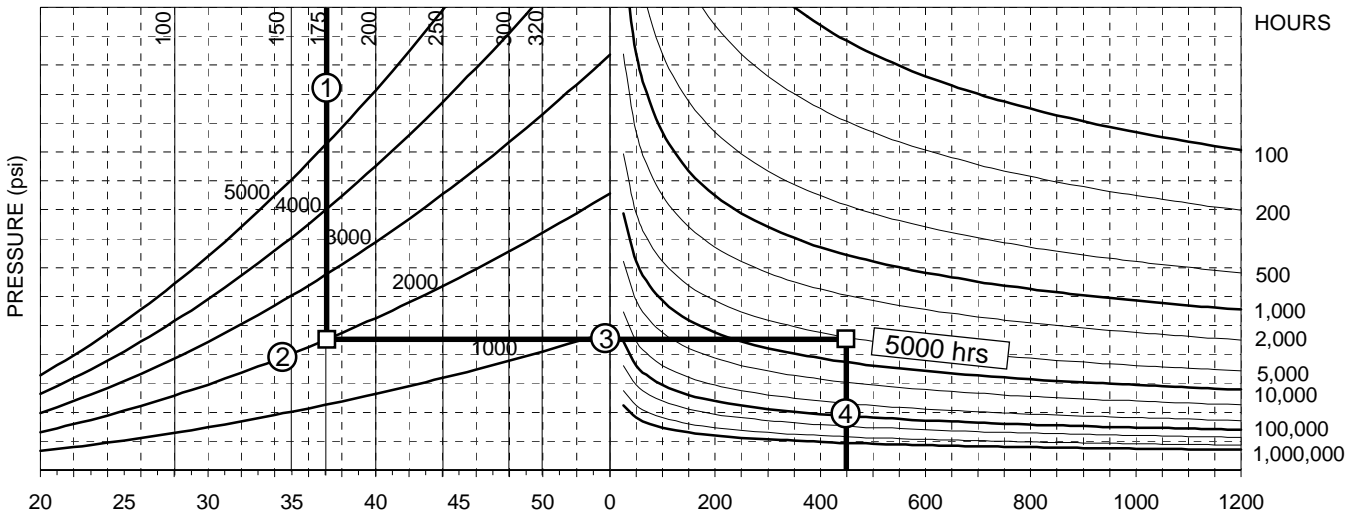

PRESSURE-LIFETIME RELATIONSHIP

Please note that a small variation in the pressure used to calculate the lifetime can produce a large difference in the calculated lifetime.

The relationship between the working pressure and the lifetime is not linear, but as shown in the graph.

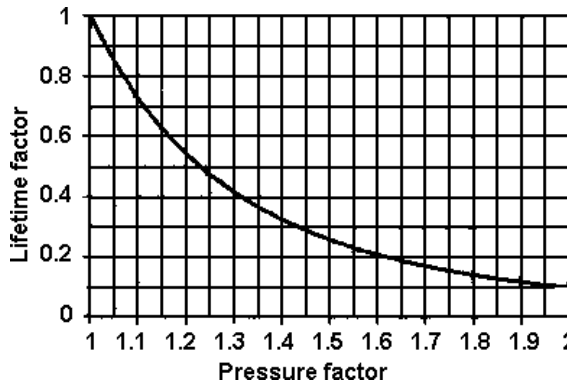

Example:

If, with 1000 psi (load factor = 1), the lifetime is 10,000 hours (lifetime factor = 1), then with 1200 psi (load factor = 1.2) the lifetime becomes 5500 hours (lifetime factor 0.55)



GM05		60	75	110	130	150	170	200
Displacement	<i>in³/rev</i>	3.59	4.51	7.04	7.87	9.20	10.14	11.64
Specific torque	<i>lb.ft/100psi</i>	4.76	5.98	9.34	10.44	12.20	13.45	15.45
Cont. pressure ¹⁾	<i>psi</i>	3550	3550	3550	3550	3550	3550	3550
Peak pressure	<i>psi</i>	6400	6000	5700	5500	5500	5000	5000
Peak press ²⁾	<i>psi</i>	8500	7800	7000	7000	-	-	-
Max. speed ³⁾	<i>rpm</i>	1200	1200	1000	1000	1000	900	800
Peak power	<i>HP</i>	50	50	50	50	50	50	50

Approximate weight: 53 lbs
 Motor casing oil capacity: 32 in³
 Max. casing pressure: 14 psi continuous
 70 psi peak

- 1) Continuous or average working pressure should be chosen in function of the bearing lifetime.
- 2) High pressure version (HP).
- 3) Speed limitation with optional low speed distributors: cont. 250 rpm, max 500 rpm (see distributors, page 46).

DIMENSIONS

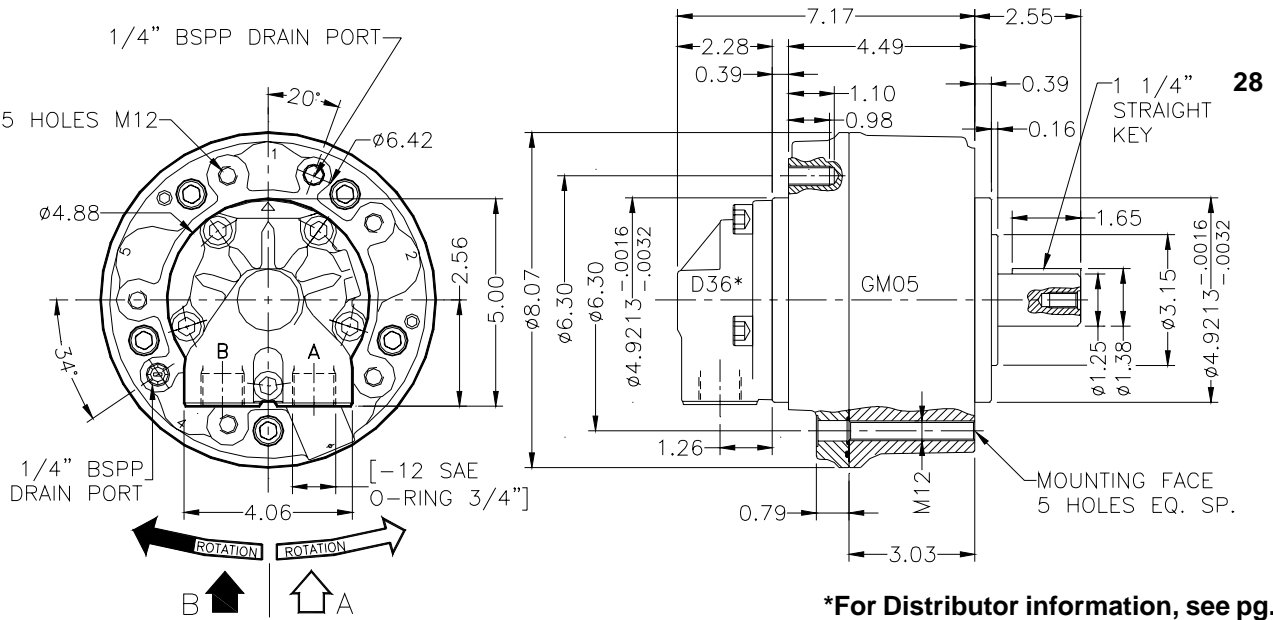

*For Distributor information, see pg. 46.

SAE SHAFT OPTIONS

See Page 52 for SAE Flanges

7/8 13 Tooth Spline 13

1 1/4 14 Tooth Spline 17

Class 6B Fit Spline 77

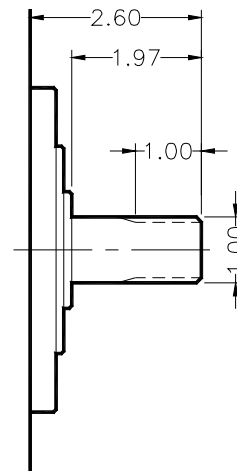
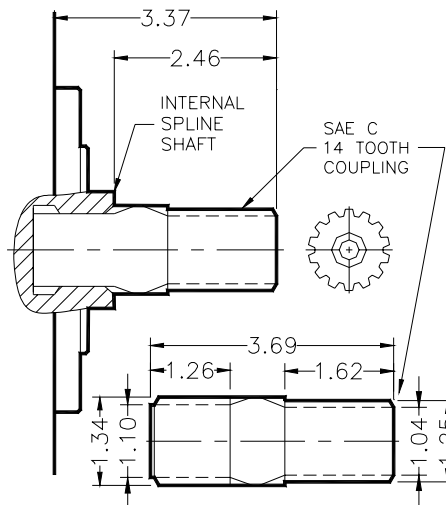
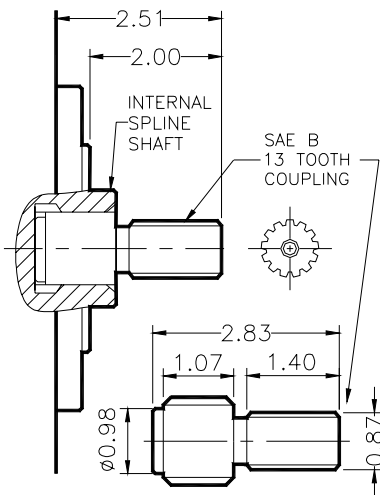

METRIC SHAFT OPTIONS

Spline DIN 5480 7
 UNI 221 1

Tapered 2

Internal Spline DIN 5480 9
 UNI 221 3

Parallel Keyed 8

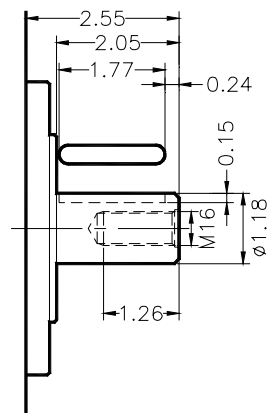
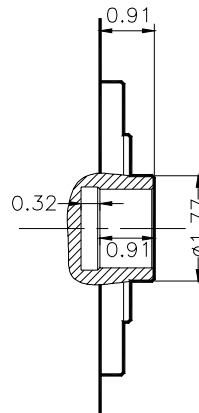
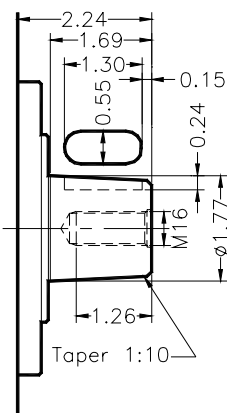
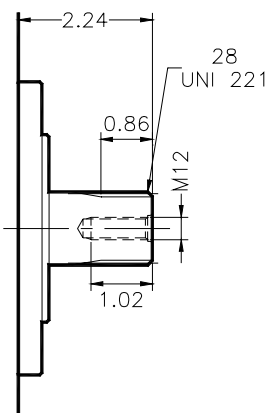

PERFORMANCE

The graphs indicate the typical performance characteristics of the GM05-110 motor operating with mineral oil with viscosity 40 cSt at 122°F.

MECHANICAL EFFICIENCY

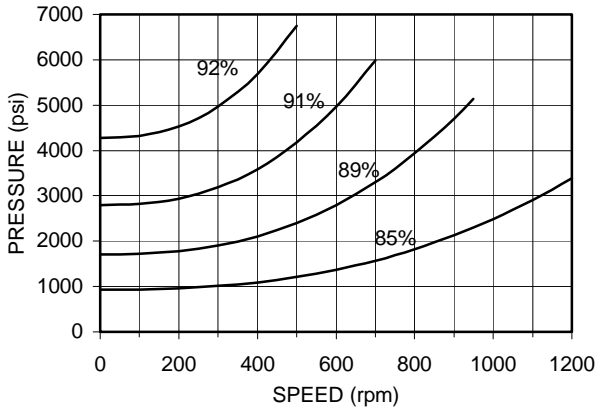

VOLUMETRIC EFFICIENCY

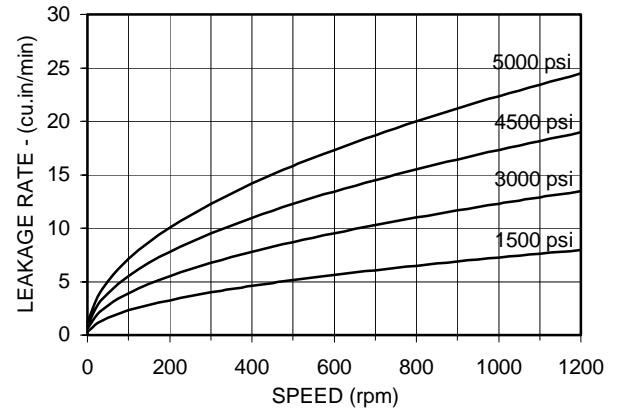

STARTING AND LOW SPEED TORQUE

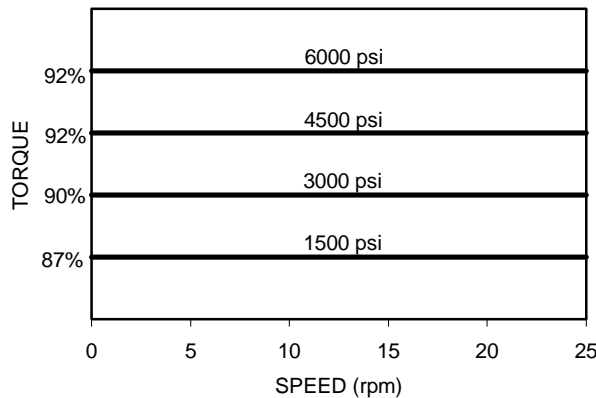

IDLING AND BOOST PRESSURE

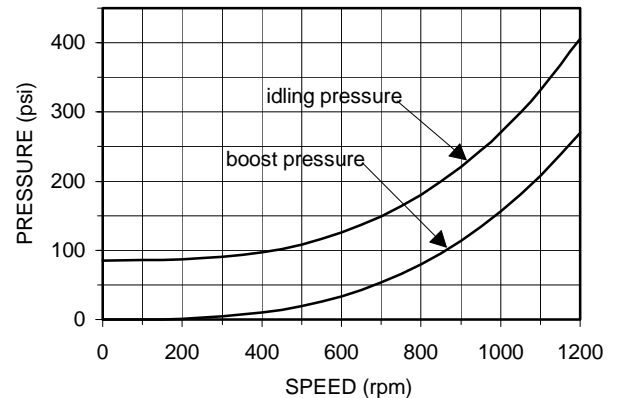

BEARING LIFETIME

The graph refers to the motor with the optional roller bearings (option H) recommended for most applications.

Note that the average lifetime of a bearing (B_{50} lifetime) is approximately 5 times the B_{10} lifetime.

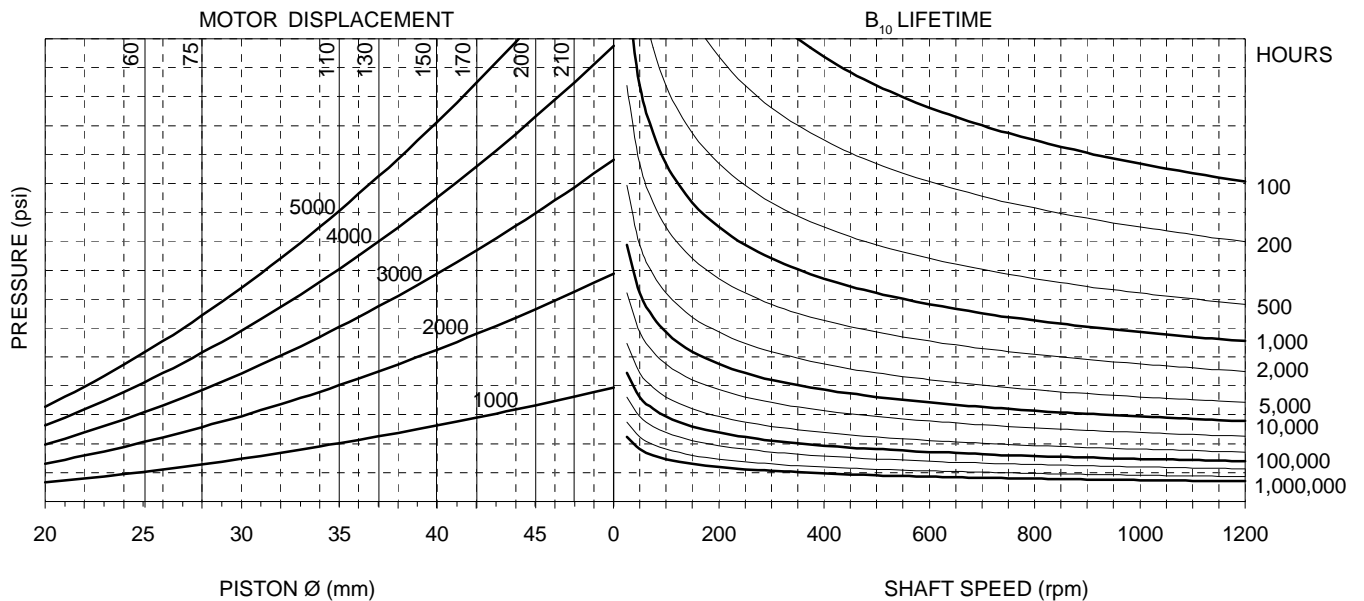

BEARING OPTIONS

For longer lifetimes, contact our technical department.

Ball bearings (standard) - the lifetime of the ball bearings is approximately 15% of the equivalent lifetime of the roller bearings "H" given in the graph.

Roller bearings (option H) - recommended for most applications. The lifetime is given in the bearing lifetime graph.

Spherical roller bearings (option G) - the lifetime is approximately 2.24 times the equivalent lifetime of the roller bearings given in the graph.

ORDER CODES

GM05	110	1	H	-	D36	-	-	-
------	-----	---	---	---	-----	---	---	---

MOTOR CODE

1. **Nominal displacement** - See motor spec. table

2. **Shaft options:**
- 7 = Ext. 35-2-16 DIN 5480 (std)
 - 1 = Ext. 28 UNI 221
 - 9 = Int. 35-2-16 DIN 5480
 - 3 = Int. 28 UNI 221
 - 2 = Tapered Keyed
 - 8 = Parallel Keyed
 - 13 = 7/8" 13 Tooth Spline
 - 17 = 11/4 14 Tooth Spline
 - 28 = 11/4 Straight Keyed
 - 77 = Class 6B Fit Spline

3. **Bearings:**

- No code = Ball Bearings
- H = Roller Bearings
- G = Spherical Roller Bearings

4. **Other options:**

- HP = High pressure version, only
GM05-65, 75, 110, 130
- U = Without shaft seal
- SV = Shaft seal protection
- VY = Viton seals
- I = Case press. relief valve
43psi.

DISTRIBUTOR CODE See Page 46

5. **Distributor:** D36 standard

6. **Tachometer:**
- K = Predisposed for tachometer
 - J = Mechanical Tach. mount
 - JB2 = Mount for BEI encoder
E25 BA (type 6R)
 - JB4 = Mount for Hall Effect switch
up to 200 pulses per rev.

ASSEMBLY CODES

7. **Direction of shaft rotation:** standard motors are supplied with clockwise rotation (viewed from shaft end) with flow in port A, out port B.

- No code = Clockwise rotation
- L = Counter-Clockwise rotation

8. **Distributor cover position:** See Page 7

- No code = Position DM1
- DM~ = Other position

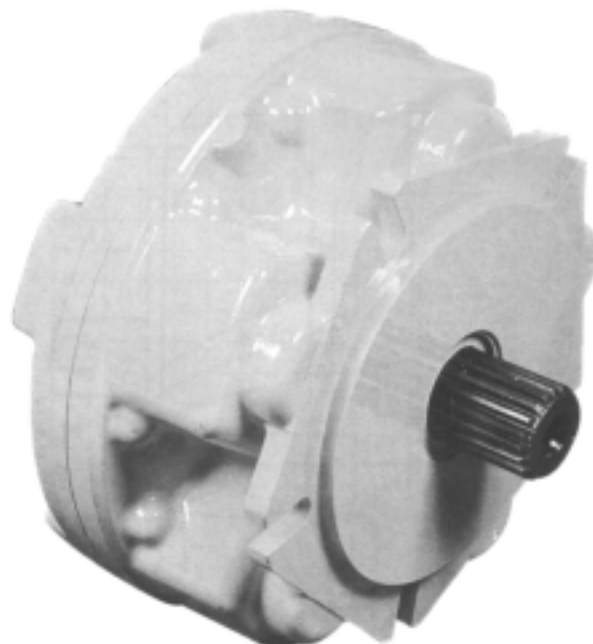
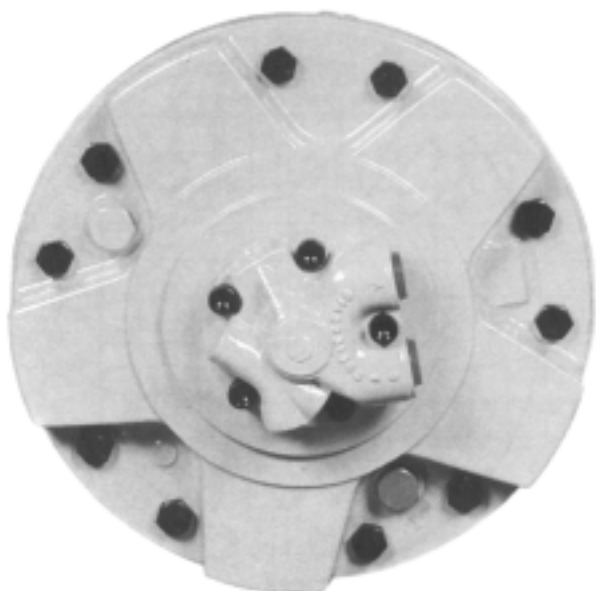

GM1		100	150	175	200	250	300	320*
Displacement	<i>in³/rev</i>	6.04	9.40	10.50	12.27	14.83	17.70	19.16
Specific torque	<i>lb.ft/100psi</i>	8.01	12.47	13.93	16.28	19.68	23.49	25.42
Cont. pressure ¹⁾	<i>psi</i>	3550	3550	3550	3550	3550	3550	3550
Peak pressure	<i>psi</i>	6400	6000	5700	5500	5500	5000	5000
Peak press ²⁾	<i>psi</i>	8500	7800	7000	-	-	-	-
Max. speed ³⁾	<i>rpm</i>	1200	1200	1200	1200	1000	900	900
Peak power	<i>HP</i>	75	75	75	75	75	75	75

* Motor has limited working pressure. Please contact SAI for specifications

Approximate weight: 60 lbs
 Motor casing oil capacity: 64 in³
 Max. casing pressure: 14 psi continuous
 70 psi peak

- 1) Continuous or average working pressure should be chosen in function of the bearing lifetime.
- 2) High pressure version (HP).
- 3) Speed limitation with optional low speed distributors: cont. 250 rpm, max 500 rpm (see distributors, page 46).

DIMENSIONS

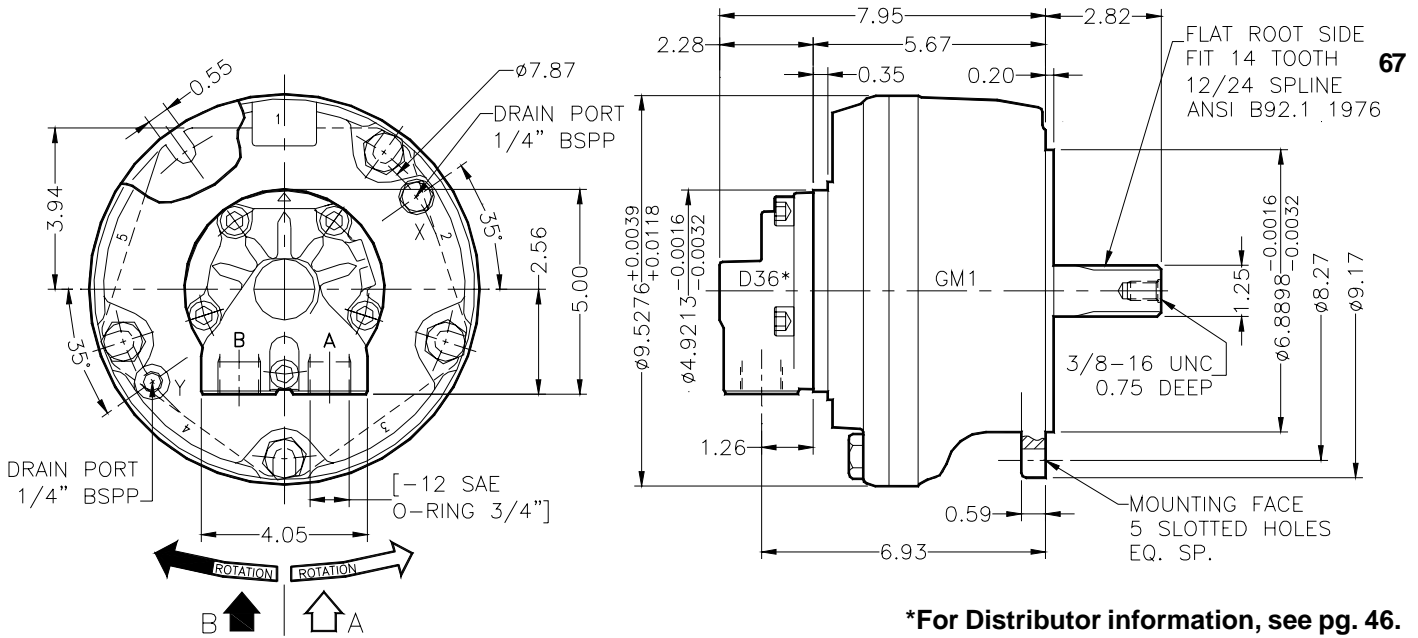

SAE SHAFT OPTIONS

SPECIAL SHAFT OPTIONS See Pg. 52 for SAE Flanges

1 1/4 Straight Keyed **58**

1 1/2 Straight Keyed **68**

1 1/4 14 Tooth Spline **37**

1 1/4 Straight Keyed **38**

1 1/2 Straight Keyed **48**

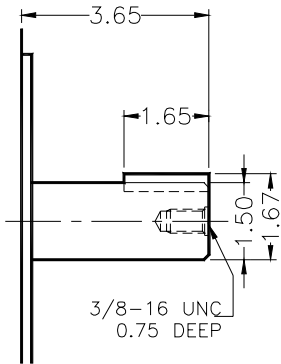
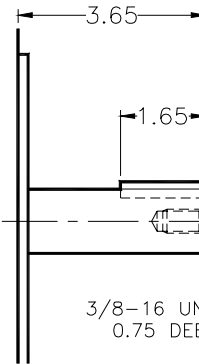
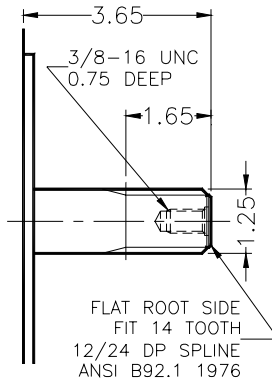
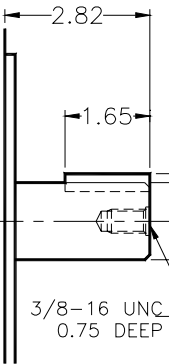
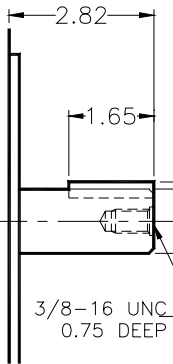

METRIC SHAFT OPTIONS

Spline DIN 5480 **7**
UNI 221 **1**

Tapered **2**

Internal Spline DIN 5480 **9**
UNI 221 **3**

Parallel Keyed **8**

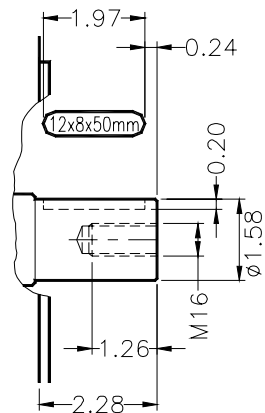
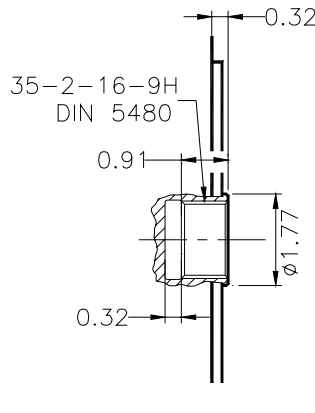
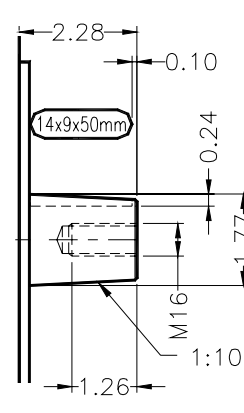
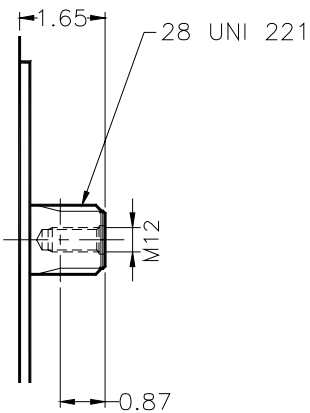

PERFORMANCE

The graphs indicate the typical performance characteristics of the GM1-150 motor operating with mineral oil with viscosity 40 cSt at 122°F.

MECHANICAL EFFICIENCY

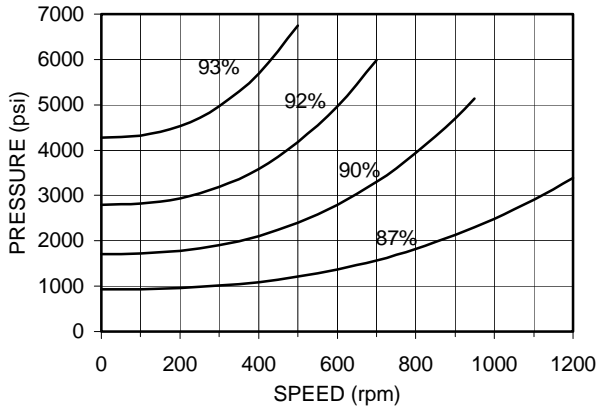

VOLUMETRIC EFFICIENCY

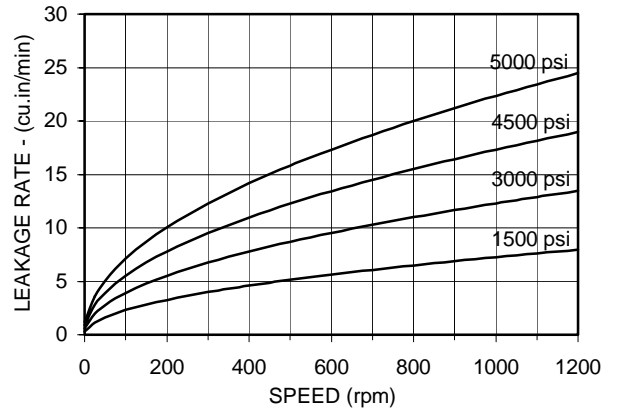

STARTING AND LOW SPEED TORQUE

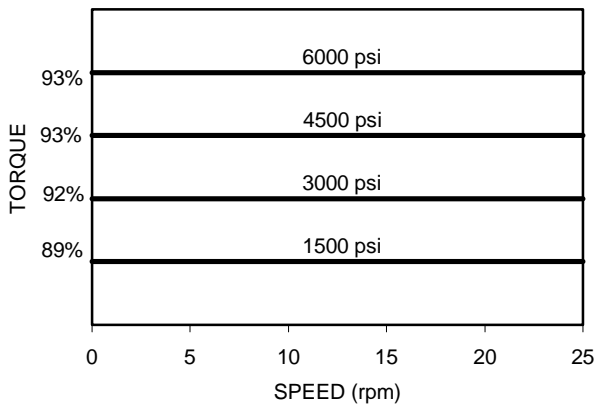

IDLING AND BOOST PRESSURE

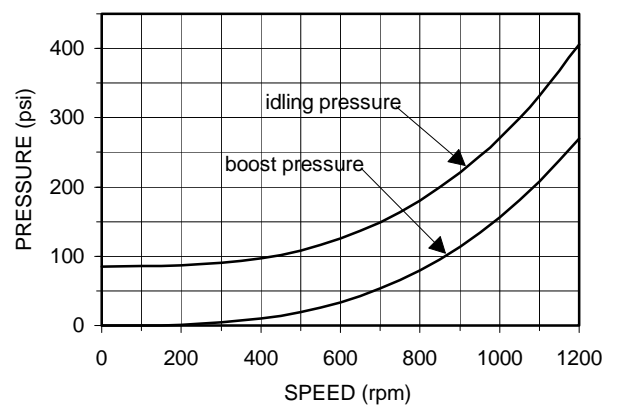

BEARING LIFETIME

The graph refers to the motor with the optional roller bearings (option H) recommended for most applications.

Note that the average lifetime of a bearing (B_{50} lifetime) is approximately 5 times the B_{10} lifetime.

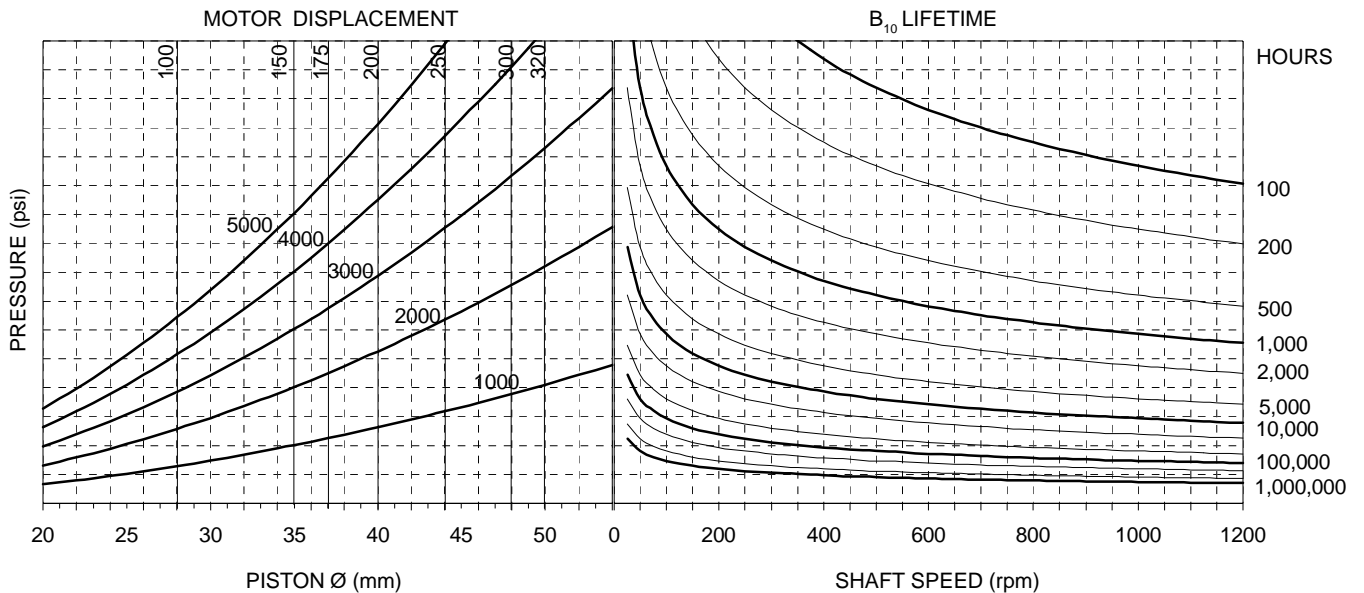

BEARING OPTIONS

For longer lifetimes, contact our technical department.

Ball bearings (standard) - the lifetime of the ball bearings is approximately 15% of the equivalent lifetime of the roller bearings "H" given in the graph.

Roller bearings (option H) - recommended for most applications. The lifetime is given in the bearing lifetime graph.

Spherical roller bearings (option G) - the lifetime is approximately 2.24 times the equivalent lifetime of the roller bearings given in the graph.

ORDER CODES

GM1	150	1	H	-	D36	-	-	-
-----	-----	---	---	---	-----	---	---	---

MOTOR CODE

1. Nominal displacement - See motor spec. table

2. Shaft options: 7 = Ext. 35-2-16 DIN 5480 (std)

1 = Ext. 28 UNI 221

9 = Int. 35-2-16 DIN 5480

3 = Int. 28 UNI 221

2 = Tapered Keyed

SAE Flange

8 = Parallel Keyed

Shaft Options:

58 = 11/4 Straight Keyed

68 = 11/2 Straight Keyed

37 = 11/4 14 Tooth Spline

38 = 11/4 Straight Keyed

48 = 11/2 Straight Keyed

3. Bearings:

No code = Ball Bearings

H = Roller Bearings

G = Spherical Roller Bearings

4. Other options:

HP = High pressure version
only GM1 100, 150, 175

U = Without shaft seal

SV = Shaft seal protection

VY = Viton seals

I = Case press. relief valve 43psi

DISTRIBUTOR CODE See Page 46

5. Distributor: D36 standard

6. Tachometer: K = Predisposed for tachometer

J = Mechanical Tach. mount

JB2 = Mount for BEI encoder
E25 BA (type 6R)

JB4 = Mount for Hall Effect switch
up to 200 pulses per rev.

ASSEMBLY CODES

7. Direction of shaft rotation: standard motors are supplied with clockwise rotation (viewed from shaft end) with flow in port A, out port B.

No code = Clockwise rotation

L = Counter-Clockwise rotation

8. Distributor cover position: See Page 7

No code = Position DM1

DM ~ = Other position

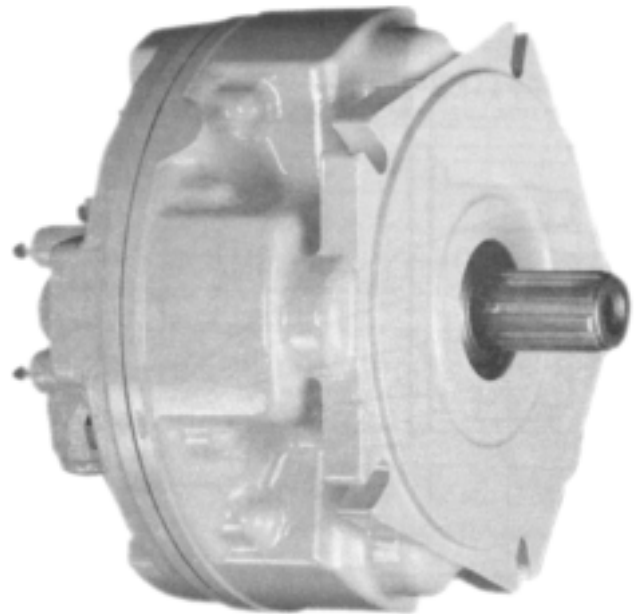
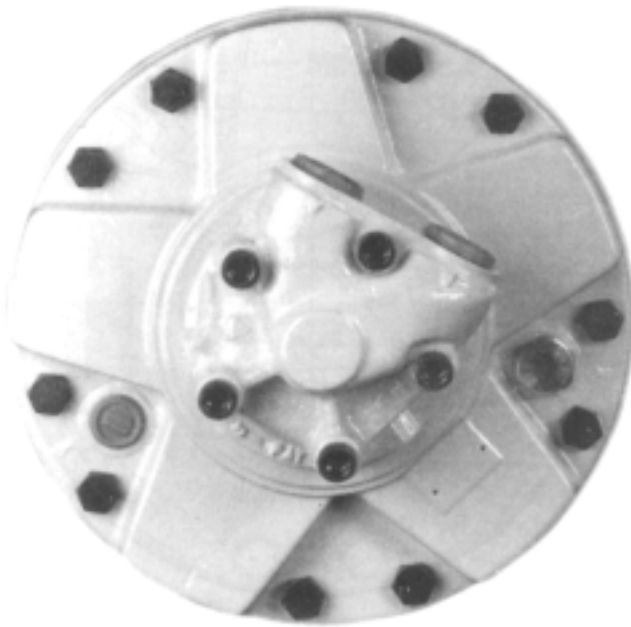

GM2		200	250	300	350	420	500	600
Displacement	<i>in³/rev</i>	11.72	15.32	18.55	21.18	25.94	30.08	34.47
Specific torque	<i>lb.ft/100psi</i>	15.55	20.33	24.62	28.11	34.42	39.92	45.74
Cont. pressure ¹⁾	<i>psi</i>	3550	3550	3550	3550	3550	3550	3550
Peak pressure	<i>psi</i>	6400	6000	5700	5700	5500	5500	5000
Peak pressure ²⁾	<i>psi</i>	8550	7800	7000	7000	-	-	-
Max. speed ³⁾	<i>rpm</i>	1000	1000	900	900	850	850	800
Peak power	<i>HP</i>	95	95	95	95	95	95	95

Approximate weight: 104 lbs
 Motor casing oil capacity: 122 in³
 Max. casing pressure: 14 psi continuous
 70 psi peak

- 1) Continuous or average working pressure should be chosen in function of the bearing lifetime.
- 2) High pressure version (HP).
- 3) Speed limitation with optional low speed distributors: cont. 250 rpm, max 500 rpm (see distributors, page 46).

DIMENSIONS

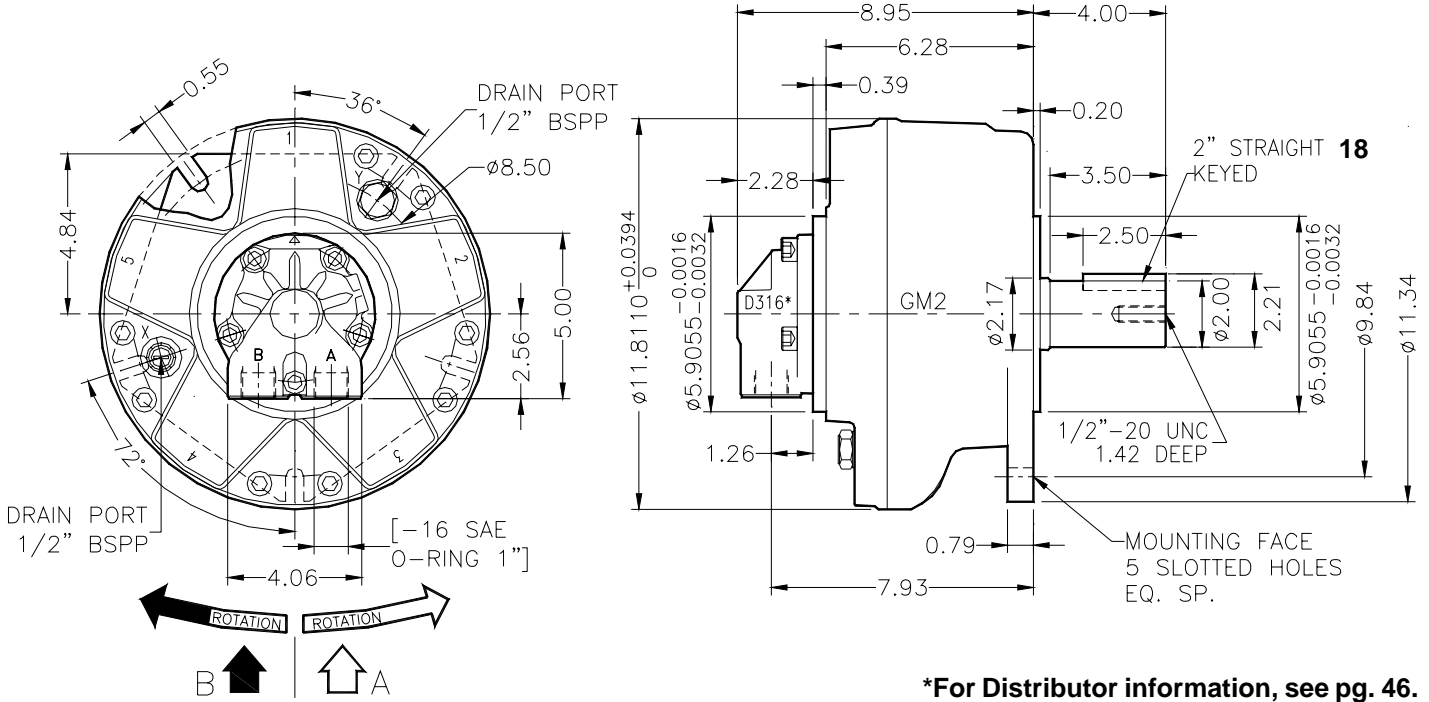

*For Distributor information, see pg. 46.

SHAFT OPTIONS

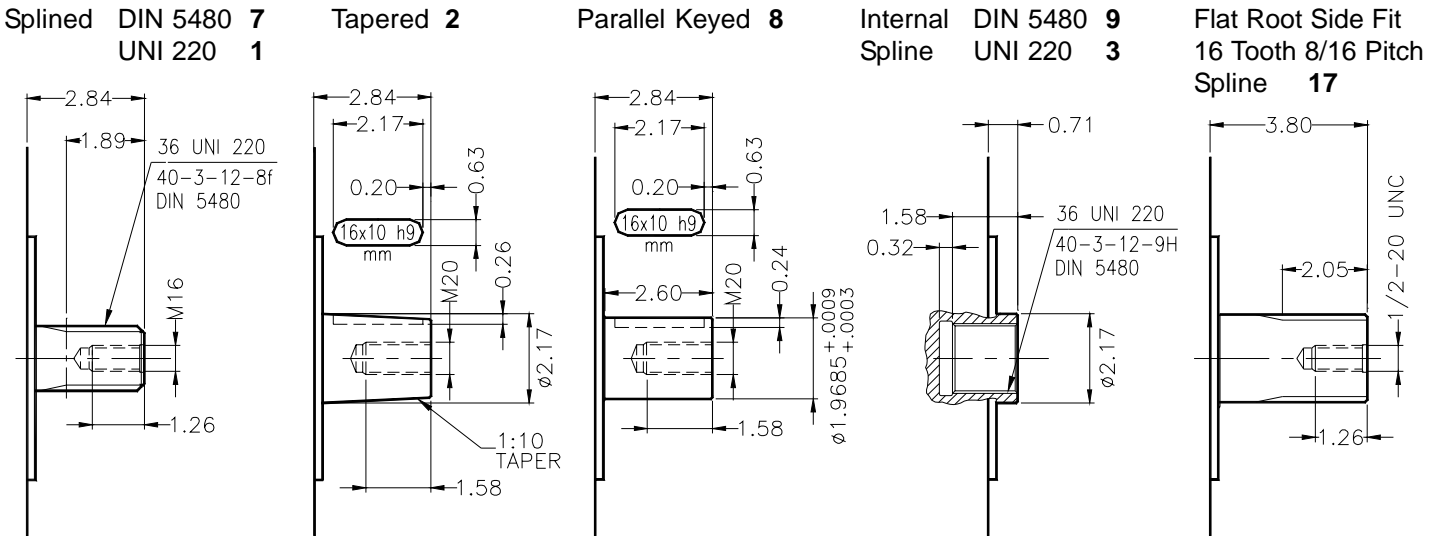

SPLINE DATA (dimensions in mm [1 in = 25.4 mm])

40-3-12 DIN 5480	
	d0 Ø36.0
	d1 Ø40.0 ^{+0.620} / ₊₀ H14
	d2 Ø34.0 ^{+0.160} / ₊₀ H11
	A Ø5.25
	da Ø28.96 ^{+0.130} / ₊₀ H11
	d3 Ø39.4 ⁻⁰ / _{-0.160} h11
	d4 Ø33.4 ⁻⁰ / _{-0.620} h14
	B Ø6.0
	db Ø45.989 ^{-0.025} / _{-0.064} f 8

36 UNI 220 (DIN 5462)	
	d1 Ø36.0 ^{+0.025} / ₊₀ H7
	d2 Ø40.0 ^{+0.160} / ₊₀ H11
	A 7.0 ^{+0.028} / _{+0.013} F7
	d3 Ø36.0 ^{-0.009} / _{-0.025} g6
	d4 Ø40.0 ^{-0.080} / _{-0.240} d11
	B 7.0 ^{-0.013} / _{-0.028} f 7

ADAPTOR

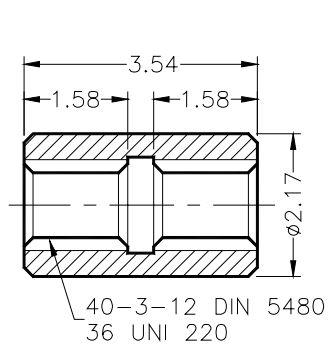

PERFORMANCE

The graphs indicate the typical performance characteristics of the GM2-300 motor operating with mineral oil with viscosity 40 cSt at 122°F.

MECHANICAL EFFICIENCY

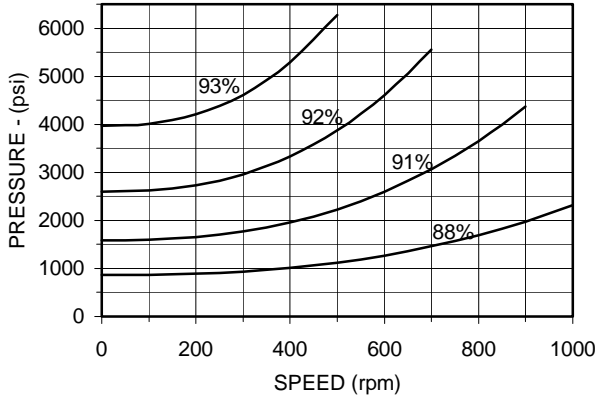

VOLUMETRIC EFFICIENCY

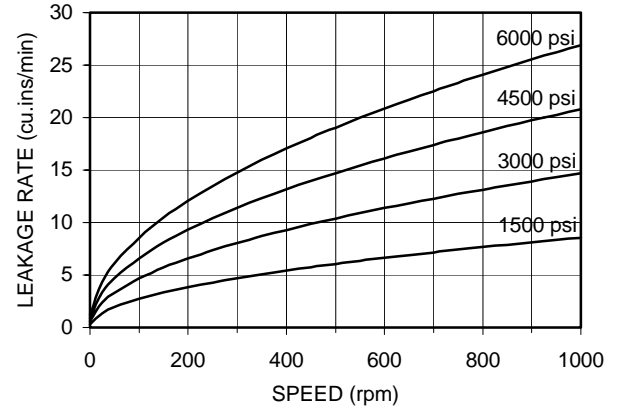

STARTING AND LOW SPEED TORQUE

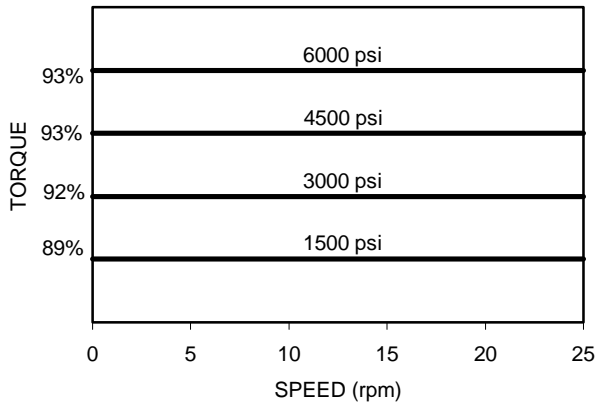

IDLING AND BOOST PRESSURE

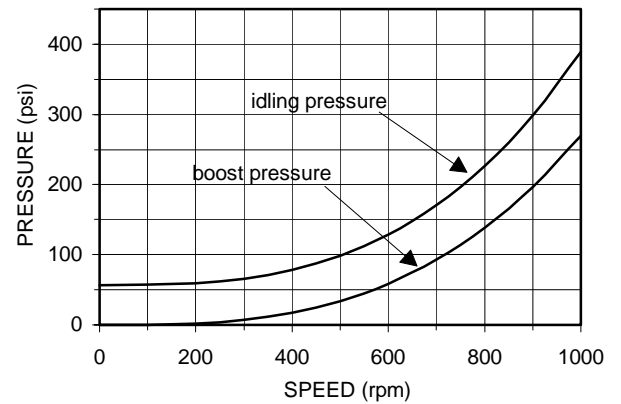

BEARING LIFETIME

The graph refers to the motor with the optional roller bearings (option H) recommended for most applications. Note that the average lifetime of a bearing (B_{50} lifetime) is approximately 5 times the B_{10} lifetime.

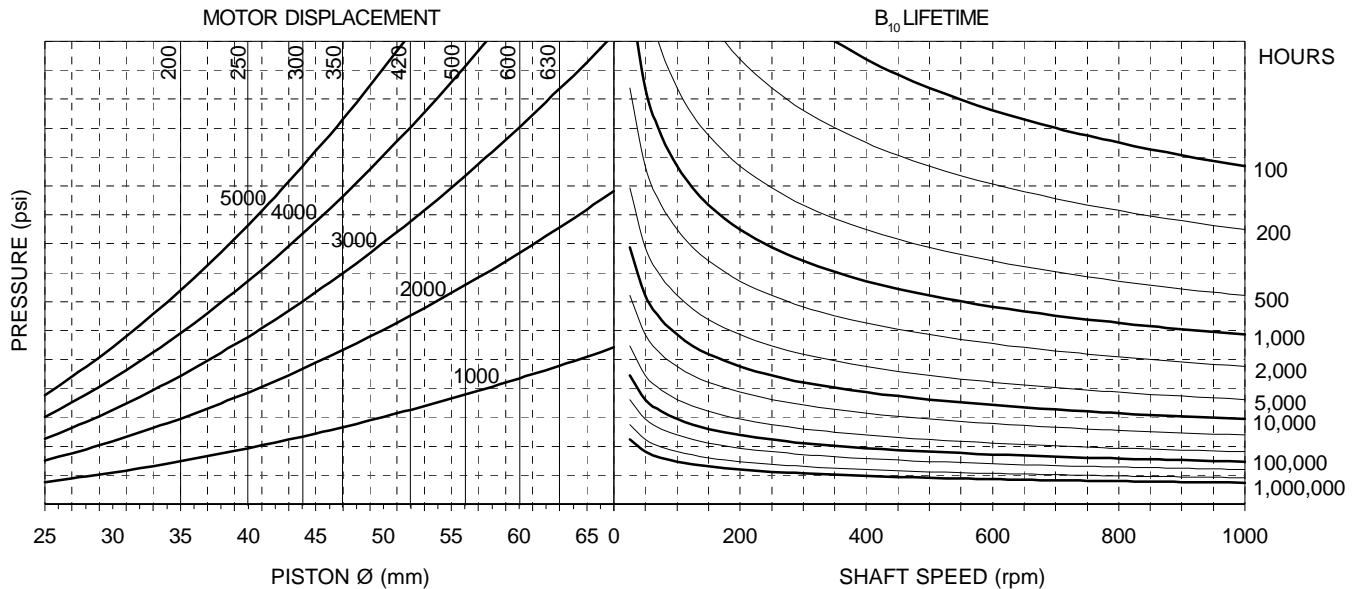

BEARING OPTIONS

For longer lifetimes, contact our technical department.

Ball bearings (standard) - the lifetime of the ball bearings is approximately 15% of the equivalent lifetime of the roller bearings "H" given in the graph.

Roller bearings (option H) - recommended for most applications. The lifetime is given in the bearing lifetime graph.

Spherical roller bearings (option G) - the lifetime is approximately 1.74 times the equivalent lifetime of the roller bearings given in the graph.

ORDER CODES

GM2	300	1	H	-	D316	-	-	-
-----	-----	---	---	---	------	---	---	---

MOTOR CODE

1. **Nominal displacement** - See motor spec. table

2. **Shaft options:** 7 = Ext. 40-3-12 DIN 5480 (std)
 1 = Ext. 36 UNI 220
 9 = Int. 40-3-12 DIN 5480
 3 = Int. 36 UNI 220
 2 = Tapered Keyed
 8 = Parallel Keyed
 18 = 2" Straight Keyed

3. **Bearings:**
 No code = Ball Bearings
 H = Roller Bearings
 G = Spherical Roller Bearings

4. **Other options:**
 HP = High pressure version
 only 200, 250, 300, 350
 U = Without shaft seal
 SV = Shaft seal protection
 VY = Viton seals
 I = Case press. relief valve
 43psi

DISTRIBUTOR CODE See page 46

5. **Distributor:** D316 standard

6. **Tachometer:** K = Predisposed for tachometer
 J = Mechanical Tach. mount
 JB2 = Mount for BEI encoder
 E25 BA (type 6R)
 JB4 = Mount for Hall Effect
 switch up to 200 pulses
 per rev.

ASSEMBLY CODES

7. **Direction of shaft rotation:** standard motors are supplied with clockwise rotation (viewed from shaft end) with flow in port A, out port B.
 No Code = Clockwise rotation
 L = Counter-Clockwise rotation

8. **Distributor cover position:** See Page 7
 No code = Position DM1
 DM~ = Other position

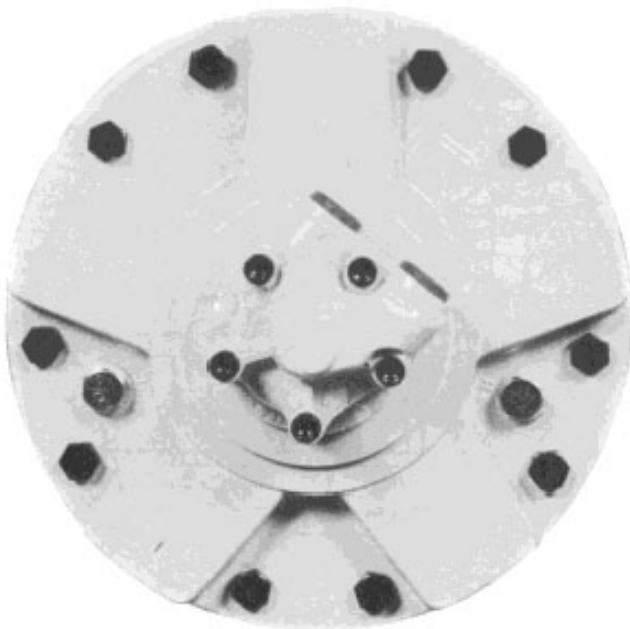

GM3/GM3A		350	425	500	600	700	800	900*	1000*
Displacement	<i>in³/rev</i>	21.48	26.00	29.66	36.31	42.12	48.33	53.27	60.23
Specific torque	<i>lb.ft/100psi</i>	28.50	34.50	39.36	48.18	55.89	64.13	70.69	79.92
Cont. pressure ¹⁾	<i>psi</i>	3550	3550	3550	3550	3550	3550	3550	3550
Peak pressure	<i>psi</i>	6400	6000	6000	5700	5500	5500	5000	5000
Peak pressure ²⁾	<i>psi</i>	8500	8500	8500	7000	-	-	-	-
Max. speed ³⁾	<i>rpm</i>	800	750	700	675	625	600	550	500
Peak power	<i>HP</i>	120	120	120	120	120	120	120	120

* not available for GM3A

Approximate weight: 143 lbs
 Motor casing oil capacity: 275 in³
 Max. casing pressure: 14 psi continuous
 70 psi peak

- 1) Continuous or average working pressure should be chosen in function of the bearing lifetime.
- 2) High pressure version (HP).
- 3) Speed limitation with optional low speed distributors: cont. 250 rpm, max 500 rpm (see distributors, page 46).

DIMENSIONS

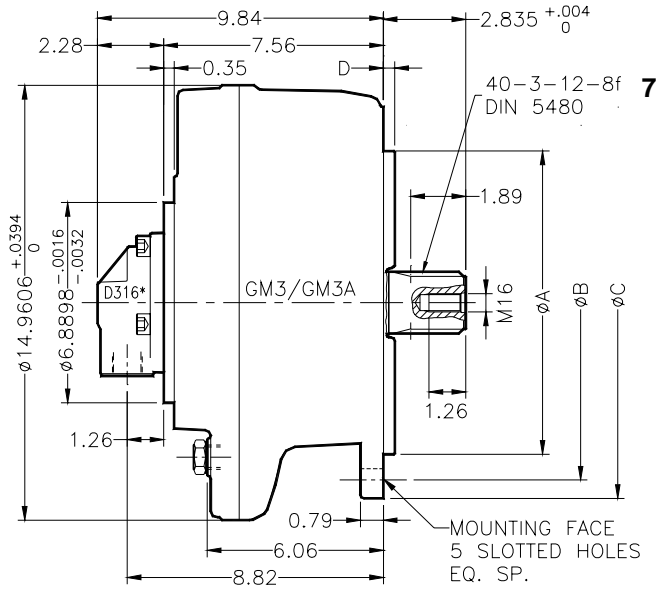
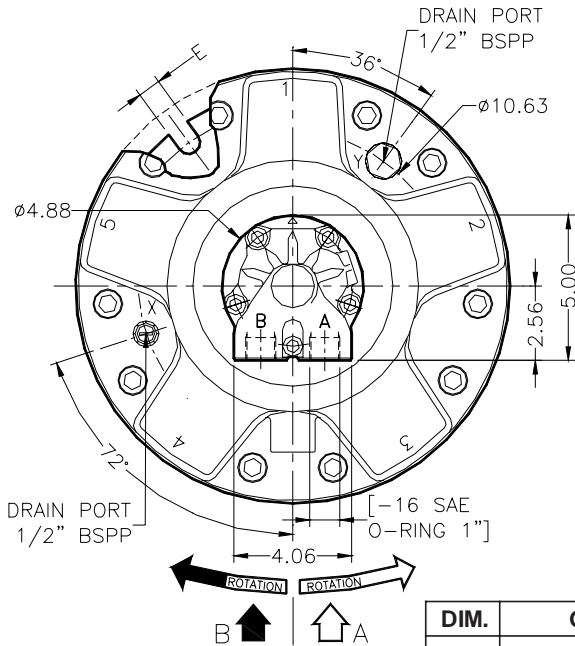

DIM.	GM3	GM3A **
A	10.4331 -0.0025 -0.0045	5.9055 -0.0016 -0.0032
B	12.205	7.677
C	13.465	9.843
D	0.39	0.20
E	0.79	0.55

*For Distributor information, see pg. 46.
**GM3A is a dimensional interchange to the M3

SHAFT OPTIONS

Splined DIN 5480 7
UNI 221 1

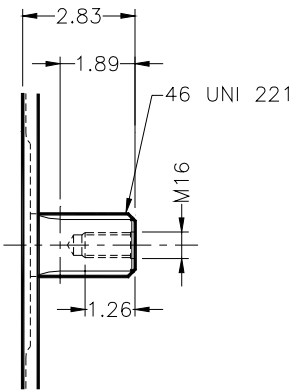

Tapered 2

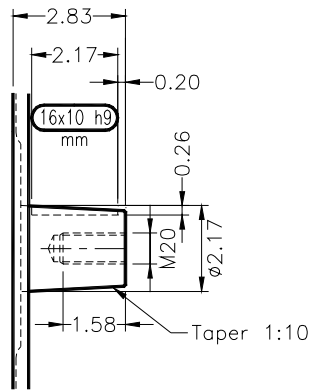

Parallel Keyed 8

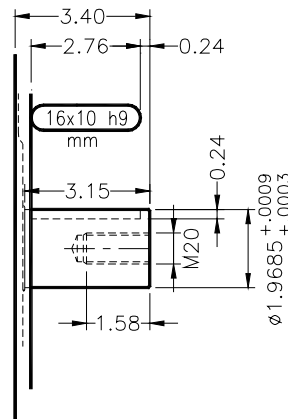

Internal DIN 5480 9
Spline UNI 220 3

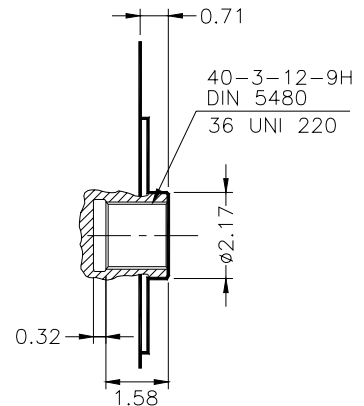

SPLINE DATA (dimensions in mm [1 in = 25.4 mm])

40-3-12 DIN 5480		46 UNI 221 (8-46-54 DIN 5463)	
	d0 Ø36.0		d1 Ø46.0 $+0.025$ $+0$ H7
	d1 Ø40.0 $+0.620$ $+0$ H14		d2 Ø54.0 $+0.190$ $+0$ H11
	d2 Ø34.0 $+0.160$ $+0$ H11		A 9.0 $+0.028$ $+0.013$ F7
	A Ø5.25		d3 Ø46.0 -0.009 -0.025 g6
	da Ø28.96 $+0.130$ $+0$ H11		d4 Ø54.0 -0.100 -0.290 d11
	d3 Ø39.4 -0 -0.160 h11		B 9.0 -0.013 -0.028 f7
	d4 Ø33.4 -0 -0.620 h14		
	B Ø6.0		
	db Ø45.989 -0.025 -0.064 f8		

ADAPTOR

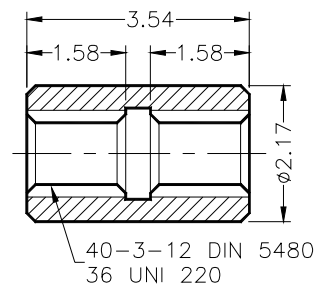

PERFORMANCE

The graphs indicate the typical performance characteristics of the GM3-600 motor operating with mineral oil with viscosity 40 cSt at 122°F.

MECHANICAL EFFICIENCY

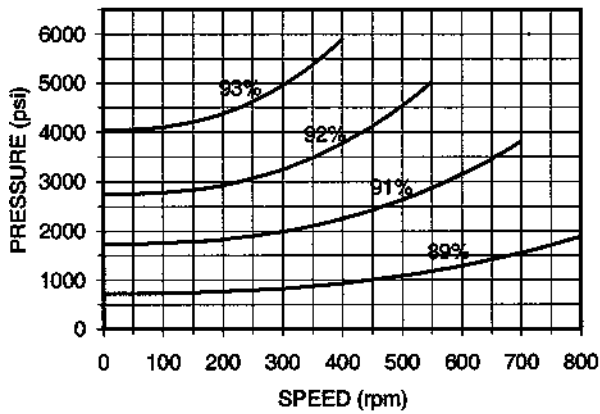

VOLUMETRIC EFFICIENCY

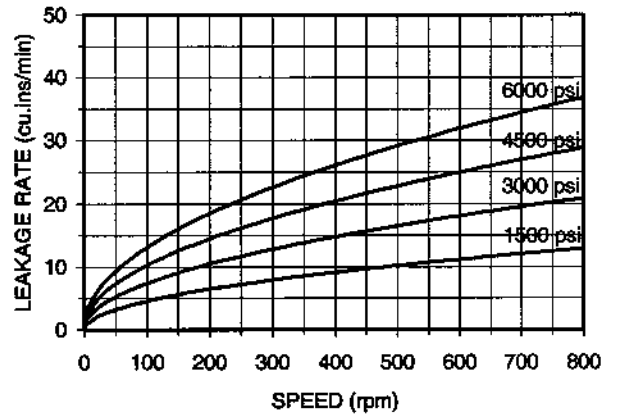

STARTING AND LOW SPEED TORQUE

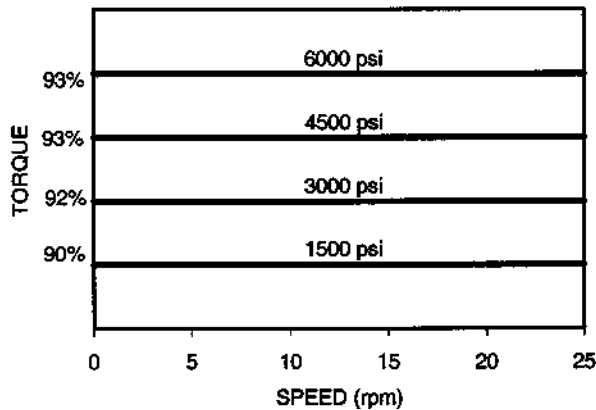

IDLING AND BOOST PRESSURE

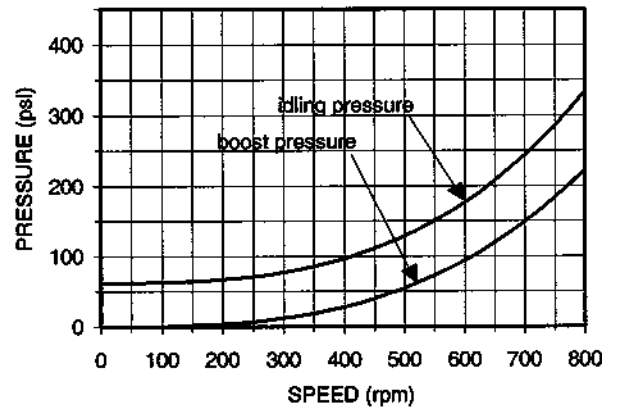

BEARING LIFETIME

The graph refers to the motor with the standard roller bearings. Note that the average lifetime of a bearing (B_{50} lifetime) is approximately 5 times the B_{10} lifetime.

MOTOR DISPLACEMENT

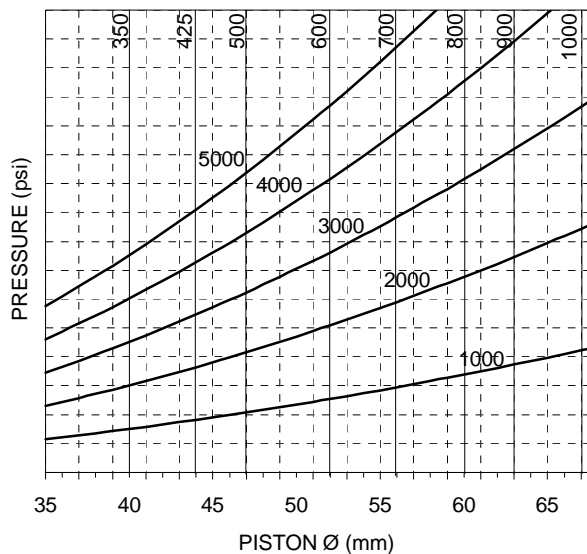

B_{10} LIFETIME

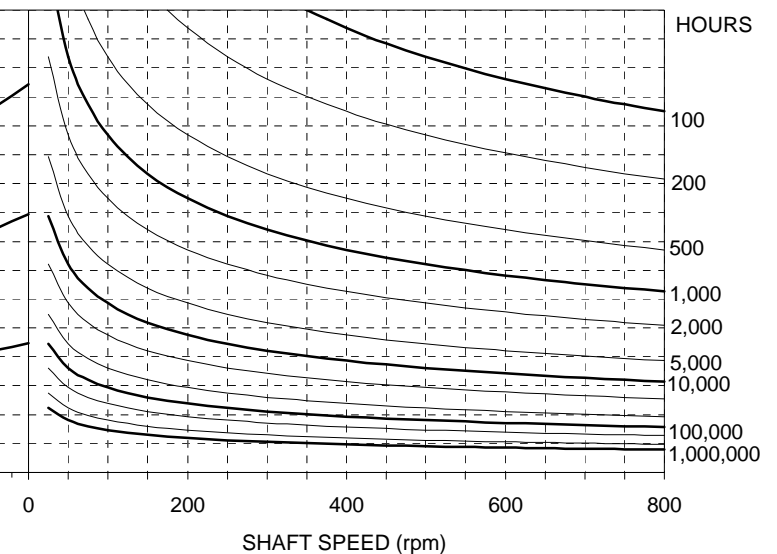

BEARING OPTIONS

For longer lifetimes, contact our technical department.

Roller bearings (standard) - recommended for most applications. The lifetime is given in the bearing lifetime graph.

Spherical roller bearings (option G) - the lifetime is approximately 5.4 times the equivalent lifetime of the standard bearings.

ORDER CODES

GM3	500	1	-	-	D316	-	-	-
-----	-----	---	---	---	------	---	---	---

MOTOR CODE

1. **Nominal displacement** - See motor spec. table

2. **Shaft options:**

- 7 = Ext. 40-3-12 DIN 5480 (std)
- 1 = Ext. 46 UNI 221
- 9 = Int. 40-3-12 DIN 5480
- 3 = Int. 36 UNI 220
- 2 = Tapered Keyed
- 8 = Parallel Keyed

3. **Bearings:**

- E = Roller bearings
- G = Spherical roller bearings

4. **Other options:**

- HP = High pressure version
only 350, 425, 500, 600
- U = Without shaft seal
- SV = Shaft seal protection
- VY = Viton seals
- I = Case press. relief valve 43psi

DISTRIBUTOR CODE See Page 46

5. **Distributor:** D316 standard

6. **Tachometer:**

- K = Predisposed for tachometer
- J = Mechanical Tach. mount
- JB2 = Mount for BEI encoder
E25 BA (type 6R)
- JB4 = Mount for Hall Effect switch
up to 200 pulses per rev.

ASSEMBLY CODES

7. **Direction of shaft rotation:** standard motors are supplied with clockwise rotation (viewed from shaft end) with flow in port A, out port B.

- No code = Clockwise rotation
- L = Counter-Clockwise rotation

8. **Distributor cover position:** See Page 7

- No code = Position DM1
- DM~ = Other position

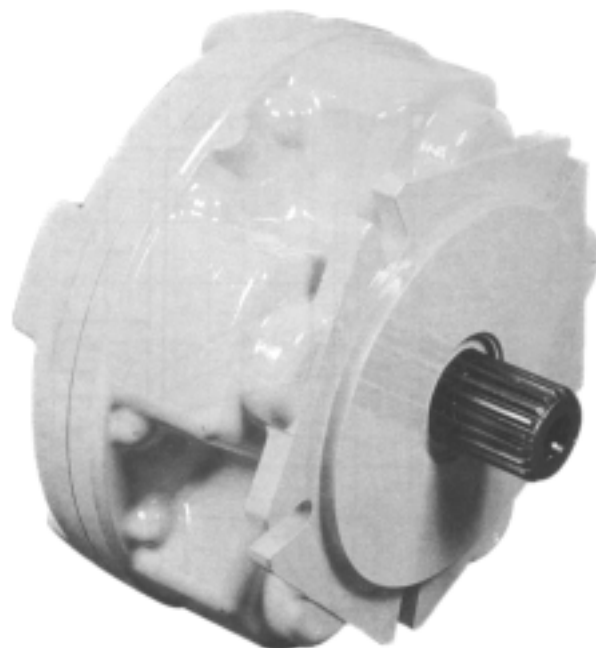
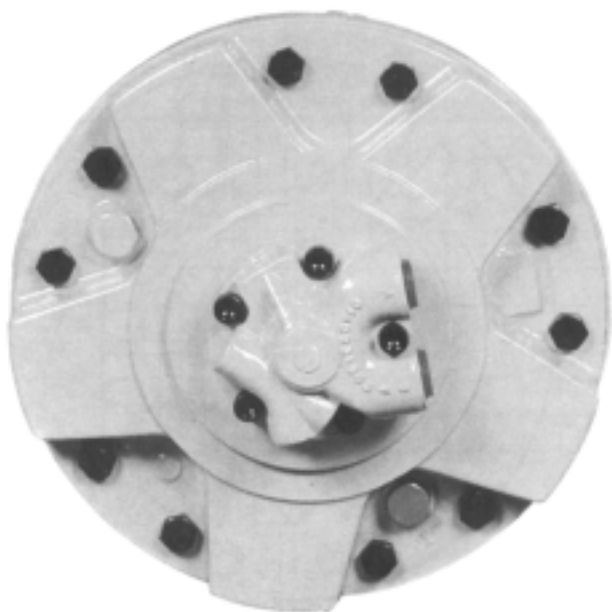

GM4		400	500	600	800	900	1000	1100	1250*	1300*
Displacement	<i>in³/rev</i>	24.53	30.70	37.59	48.39	55.17	62.37	68.10	76.10	80.31
Specific torque	<i>lb.ft/100psi</i>	32.55	40.74	49.88	64.21	73.21	82.76	90.36	100.98	106.57
Cont. pressure ¹⁾	<i>psi</i>	3550	3550	3550	3550	3550	3550	3550	3550	3550
Peak pressure	<i>psi</i>	6400	6400	6000	5700	5700	5500	5500	5000	5000
Peak press. ²⁾	<i>psi</i>	8500	8500	8500	7000	7000	-	-	-	-
Max. speed ³⁾	<i>rpm</i>	700	650	625	550	500	450	425	400	375
Peak power	<i>HP</i>	150	150	150	150	150	150	150	150	150

* Motor has limited working pressure. Please contact SAI for specifications.

Approximate weight: 220 lbs
 Motor casing oil capacity: 1.7 gallons
 Max. casing pressure: 14 psi continuous
 70 psi peak

- 1) Continuous or average working pressure should be chosen in function of the bearing lifetime.
- 2) High pressure version (HP).
- 3) Speed limitation with optional low speed distributors: cont. 250 rpm, max 500 rpm (see distributors, page 46).

DIMENSIONS

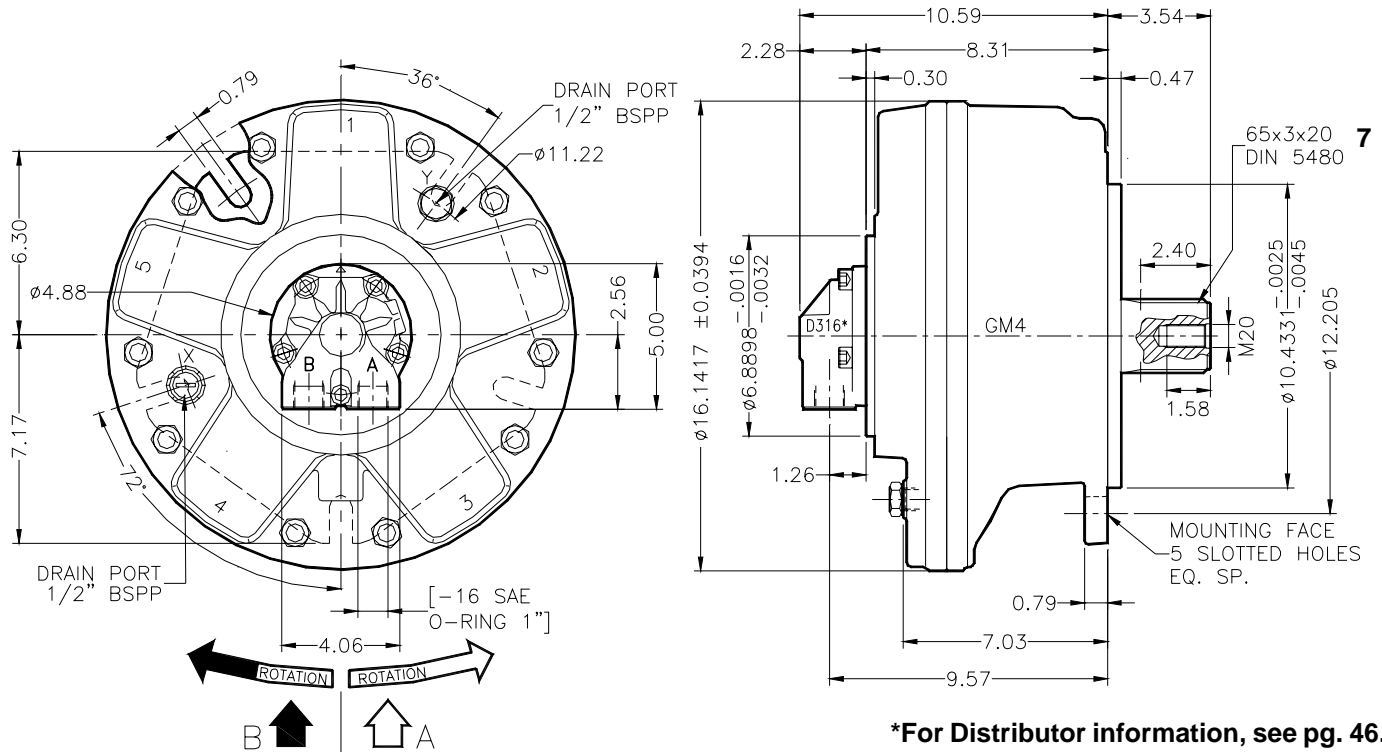

*For Distributor information, see pg. 46.

SHAFT OPTIONS

Splined DIN 5480 **7**
UNI 220 **1**

Tapered **2**

Parallel Keyed **8**

Internal DIN 5480 **9**
Spline DIN 5482 **3**

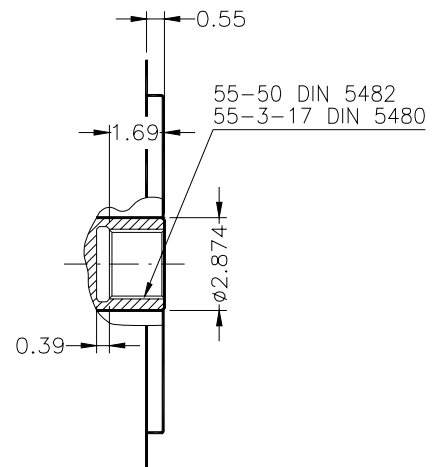
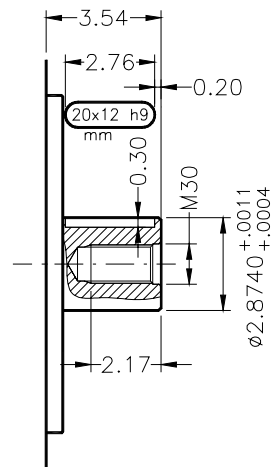
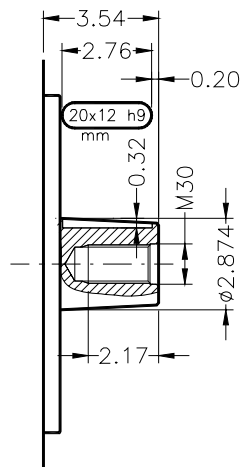
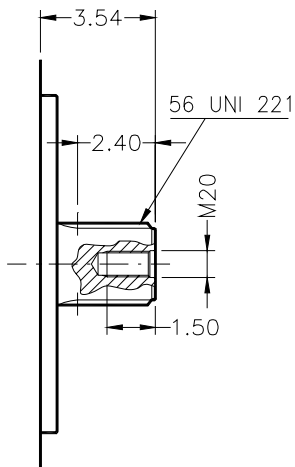

SPLINE DATA (dimensions in mm [1 in = 25.4 mm])

DIN	65-3-20 DIN 5480	55-2-26 DIN 5482	55-3-17 DIN 5480	56 UNI 221
	d0 Ø60.0	Ø52.0	Ø51.0	d1 Ø56.0 ^{+0.030} / ₊₀ H7
	d1 Ø65.0 ^{+0.740} / ₊₀ H14	Ø55.0 ^{+0.300} / ₊₀ H12	Ø55.0 ^{+0.740} / ₊₀ H14	d2 Ø65.0 ^{+0.190} / ₊₀ H11
	d2 Ø59.0 ^{+0.190} / ₊₀ H11	Ø50.0 ^{+0.160} / ₊₀ H11	Ø49.0 ^{+0.160} / ₊₀ H11	A 10.0 ^{+0.028} / _{+0.013} F7
	A Ø5.25	Ø3.5	Ø5.25	d3 Ø56.0 ^{-0.010} / _{-0.029} g6
	da Ø54.101 ^{+0.190} / ₊₀ H11	Ø46.902 ^{+0.100} / ₊₀ H10	Ø43.807 ^{+0.160} / ₊₀ H11	d4 Ø65.0 ^{-0.100} / _{-0.290} d11
	d3 Ø64.4 ⁻⁰ / _{-0.190} h11	Ø54.5 ⁻⁰ / _{-0.190} h11	Ø54.4 ⁻⁰ / _{-0.190} h11	B 10.0 ^{-0.013} / _{-0.028} f7
	d4 Ø58.4 ⁻⁰ / _{-0.740} h14	Ø49.0 ⁻⁰ / _{-0.300} h12	Ø48.4 ⁻⁰ / _{-0.620} h14	
	B Ø6.0	Ø3.5	Ø6.0	
	db Ø70.999 ^{-0.030} / _{-0.076} f8	Ø56.953 ^{-0.060} / _{-0.134} e9	Ø60.873 ^{-0.030} / _{-0.076} f8	
UNI				

ADAPTOR

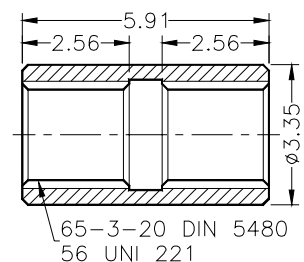

PERFORMANCE

The graphs indicate the typical performance characteristics of the GM4-900 motor operating with mineral oil with viscosity 40 cSt at 122°F.

MECHANICAL EFFICIENCY

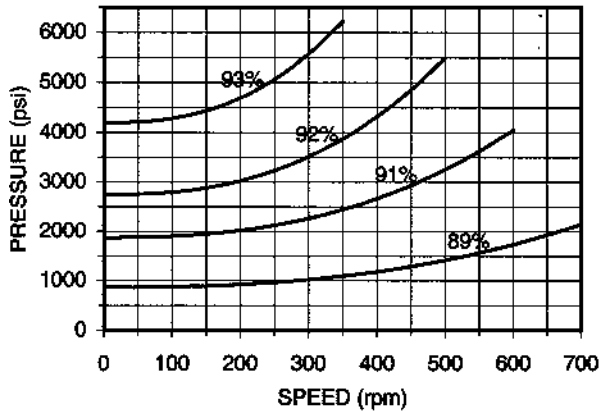

VOLUMETRIC EFFICIENCY

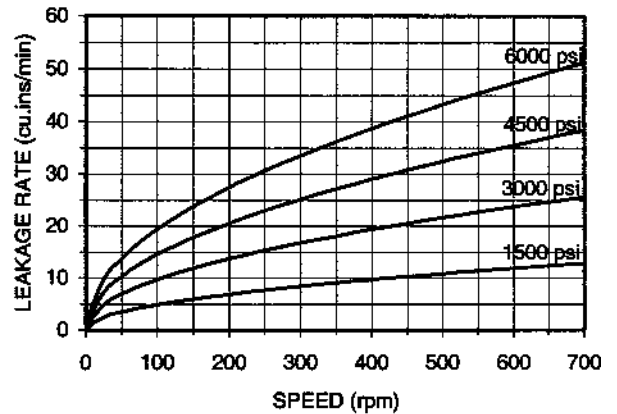

STARTING AND LOW SPEED TORQUE

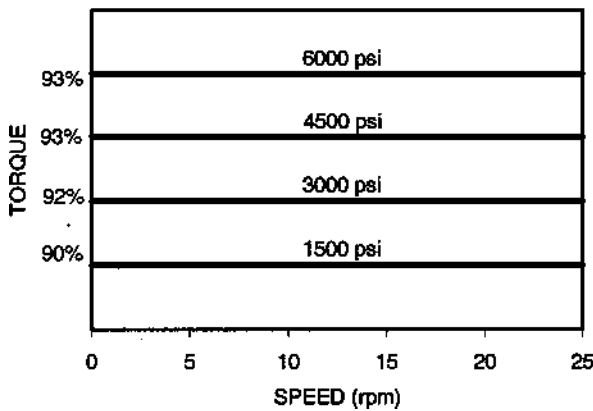

IDLING AND BOOST PRESSURE

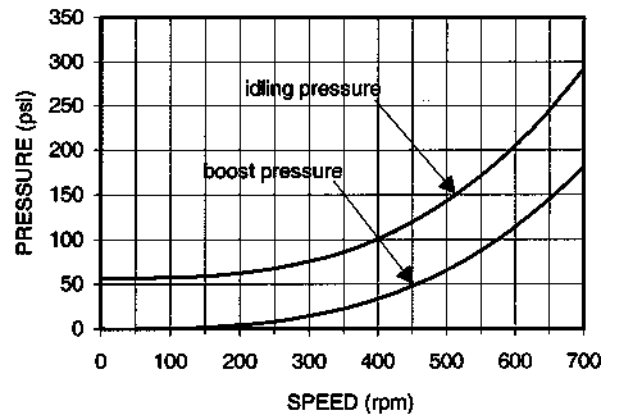

BEARING LIFETIME

The graph refers to the motor with the standard roller bearings. Note that the average lifetime of a bearing (B_{50} lifetime) is approximately 5 times the B_{10} lifetime.

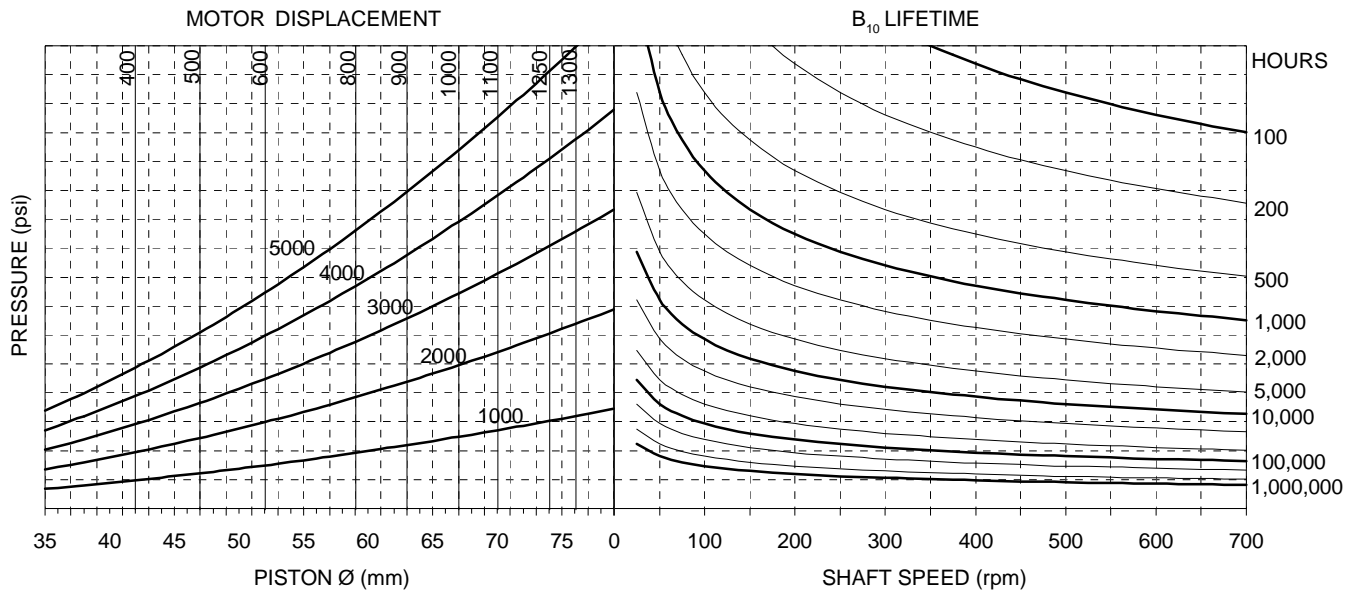

BEARING OPTIONS

For longer lifetimes, contact our technical department.

Roller bearings (standard) - The lifetime of the roller bearings is given in the bearing lifetime graph.

Spherical roller bearings (option G) - the lifetime is approximately 1.02 times the equivalent lifetime of the standard bearings.

ORDER CODES

GM4	800	1	-	-	D316	-	-	-
-----	-----	---	---	---	------	---	---	---

MOTOR CODE

1. **Nominal displacement** - See motor spec. table

2. **Shaft options:**

- 7 = Ext. 65-3-20 DIN 5480
- 1 = Ext. 56 UNI 221
- 9 = Int. 55-3-17 DIN 5480
- 3 = Int. A 55-50 DIN 5482
- 2 = Tapered Keyed
- 8 = Parallel Keyed

3. **Bearings:**

- No code = Roller bearings
- G = Spherical roller bearings

4. **Other options:**

- HP = High pressure version
only 400, 500, 600, 800, 900
- U = Without shaft seal
- SV = Shaft seal protection
- VY = Viton seals
- I = Case press. relief valve 43psi

DISTRIBUTOR CODE See Page 46

5. **Distributor:** D316 standard

6. **Tachometer:** K = Predisposed for tachometer
 J = Mechanical Tach. mount
 JB2 = Mount for BEI encoder
 E25 BA (type 6R)
 JB4 = Mount for Hall Effect switch
 up to 200 pulses per rev.

ASSEMBLY CODES

7. **Direction of shaft rotation:** standard motors
 are supplied with clockwise rotation
 (viewed from shaft end) with flow in port A, out
 port B.

- No code = Clockwise rotation
- L = Counter-Clockwise rotation

8. **Distributor cover position:** See Page 7

- No code = Position DM1
- DM~ = Other position

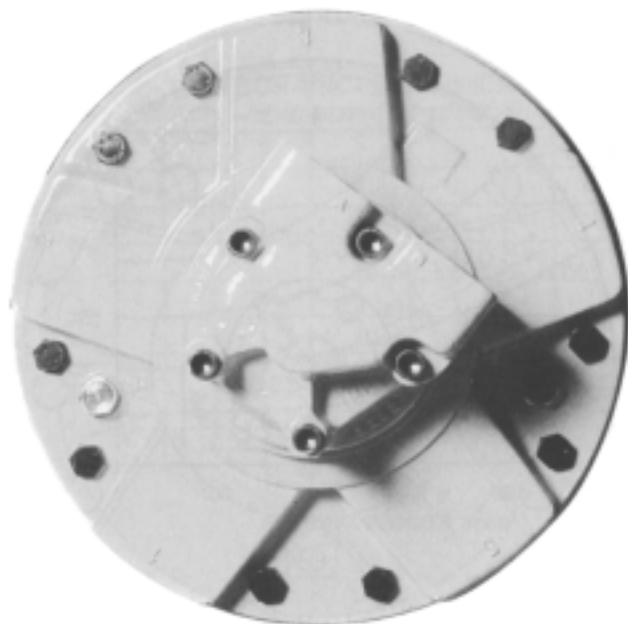

GM5A		525	650	800	1000	1200	1300	1450	1600	1800	2000
Displacement	<i>in³/rev</i>	32.10	40.21	49.25	63.40	72.31	81.77	89.22	99.71	110.80	122.50
Specific torque	<i>lb.ft/100psi</i>	42.60	53.36	65.35	84.13	95.95	108.51	118.39	132.31	147.03	162.55
Cont. pressure ¹⁾	<i>psi</i>	3550	3550	3550	3550	3550	3550	3550	3550	3550	3550
Peak pressure	<i>psi</i>	6400	6400	6000	6000	5700	5700	5500	5500	5000	5000
Peak press. ²⁾	<i>psi</i>	8500	8500	7000	7000	7000	7000	-	-	-	-
Max. speed ³⁾	<i>rpm</i>	700	650	625	550	500	450	425	400	375	325
Peak power	<i>HP</i>	190	190	190	190	190	190	190	190	190	190

Approximate weight: 286 lbs

Motor casing oil capacity: 2.6 gallons

Max. casing pressure: 14 psi continuous
70 psi peak

- 1) Continuous or average working pressure should be chosen in function of the bearing lifetime.
- 2) High pressure version (HP).
- 3) Speed limitation with optional low speed distributors: cont. 250 rpm, max 500 rpm (see distributors, page 46).

PERFORMANCE

The graphs indicate the typical performance characteristics of the GM5A-1200 motor operating with mineral oil with viscosity 40 cSt at 122°F.

MECHANICAL EFFICIENCY

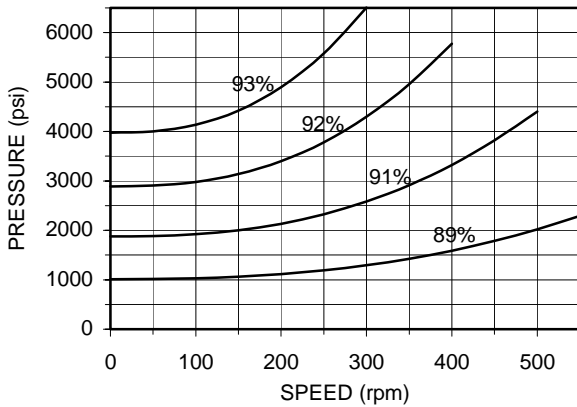

VOLUMETRIC EFFICIENCY

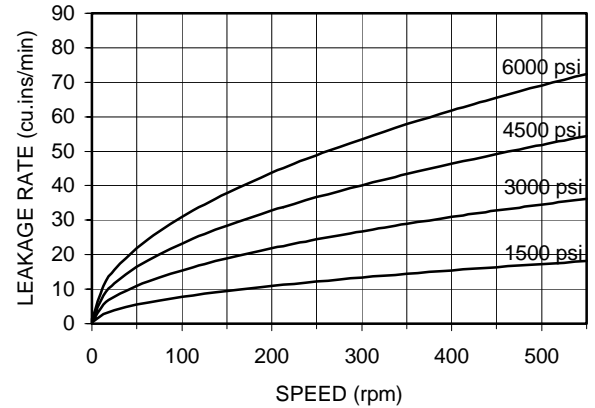

STARTING AND LOW SPEED TORQUE

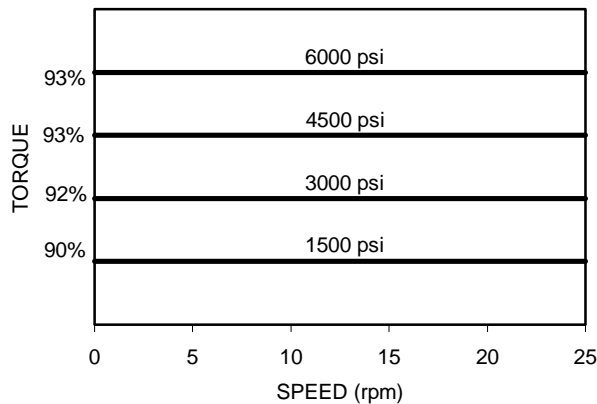

IDLING AND BOOST PRESSURE

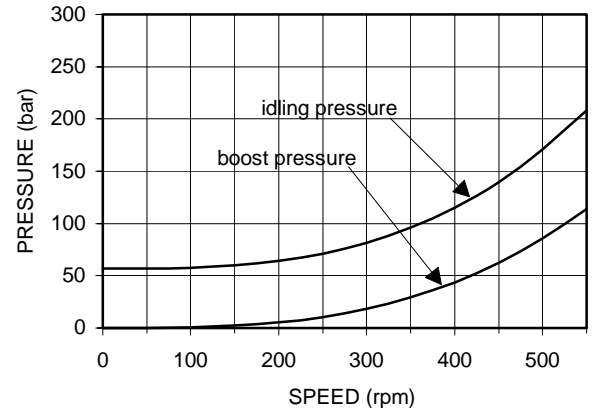

BEARING LIFETIME

The graph refers to the motor with the standard roller bearings. Note that the average lifetime of a bearing (B_{50} lifetime) is approximately 5 times the B_{10} lifetime.

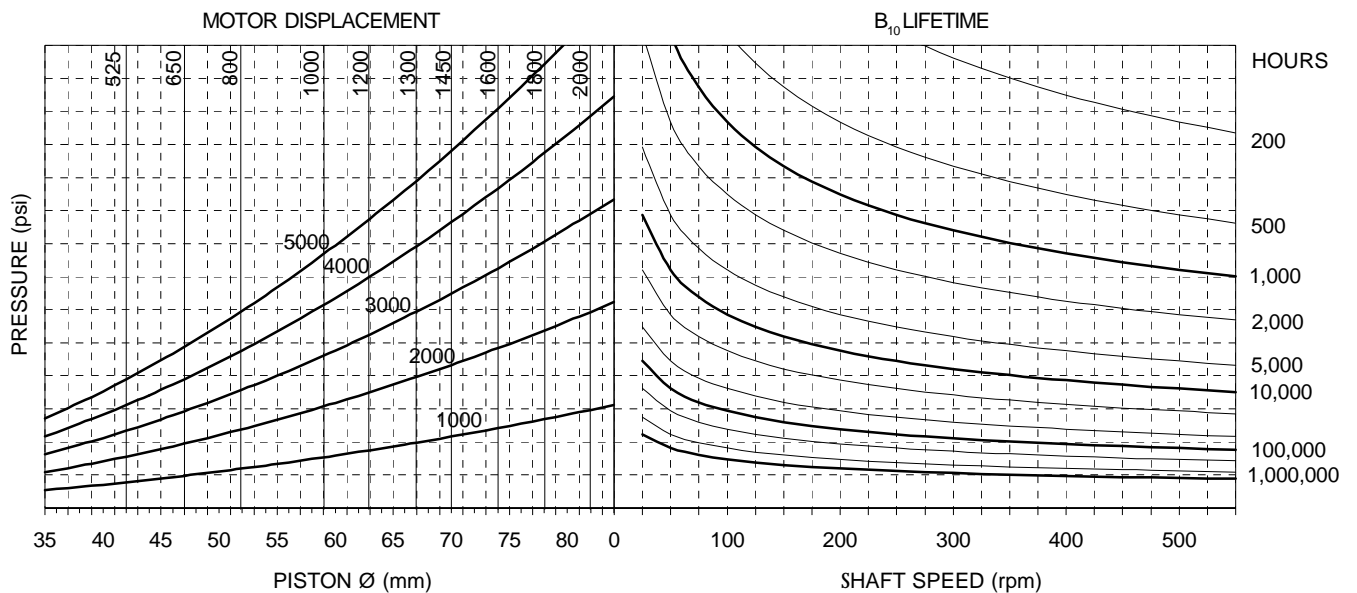

BEARING OPTIONS

For longer lifetimes, contact our technical department.

Roller bearings (standard) - recommended for most applications. The lifetime is given in the bearing lifetime graph.

Spherical roller bearings (option G) - the lifetime is approximately 0.91 times the equivalent lifetime of the standard bearings.

ORDER CODES

GM5A	1000	1	-	-	D40	-	-	-
------	------	---	---	---	-----	---	---	---

MOTOR CODE

1. **Nominal displacement** - See motor spec. table

2. **Shaft options:**

- 7 = Ext. 65-3-20 DIN 5480 (std)
- 1 = Ext. 56 UNI 221
- 9 = Int. 55-3-17 DIN 5480
- 3 = Int. 55-50 DIN 5482
- 2 = Tapered Keyed
- 8 = Parallel Keyed

3. **Bearings:**

- No code = Roller bearings
- G = Spherical roller bearings

4. **Other options:**

- HP = High pressure version
only 525, 650, 800,
1000, 1200, 1300
- U = Without shaft seal
- SV = Shaft seal protection
- VY = Viton seals
- I = Case press. relief valve 43psi

DISTRIBUTOR CODE See Page 46

5. **Distributor:** D316 standard

6. **Tachometer:**

- K = Predisposed for tachometer
- J = Mechanical Tach. mount
- JB2 = Mount for BEI encoder
E25 BA (type 6R)
- JB4 = Mount for Hall Effect switch
up to 200 pulses per rev.

ASSEMBLY CODES

7. **Direction of shaft rotation:** standard motors are supplied with clockwise rotation (viewed from shaft end) with flow in port A, out port B.

- No code = Clockwise rotation
- L = Counter-Clockwise rotation

8. **Distributor cover position:** See Page 7

- No code = Position DM1
- DM~ = Other position



GM6		1700	2100	2500	3000
Displacement	<i>in³/rev</i>	103.10	129.80	153.40	185.60
Specific torque	<i>lb.ft/100psi</i>	136.81	172.24	203.56	246.28
Cont. pressure ¹⁾	<i>psi</i>	3550	3550	3550	3550
Peak pressure	<i>psi</i>	6400	5700	5500	5000
Peak press. ²⁾	<i>psi</i>	8500	7000	-	-
Max. speed	<i>rpm</i>	400	350	300	250
Peak power	<i>HP</i>	270	270	270	270

Approximate weight: 530 lbs

Motor casing oil capacity: 6.6 gallons

Max. casing pressure: 14 psi continuous
70 psi peak

- 1) Continuous or average working pressure should be chosen in function of the bearing lifetime.
- 2) High pressure version (HP).

PERFORMANCE

The graphs indicate the typical performance characteristics of the GM6-2500 motor operating with mineral oil with viscosity 40 cSt at 122°F.

MECHANICAL EFFICIENCY

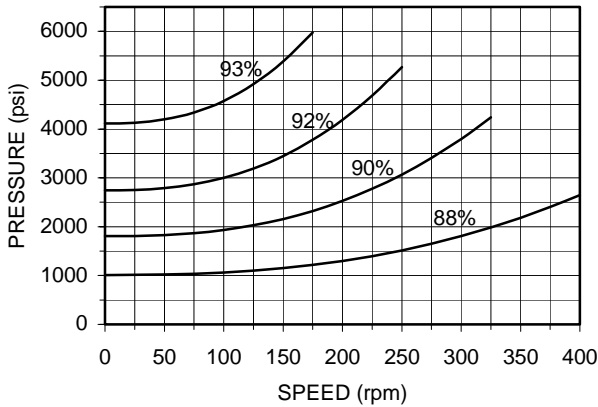

VOLUMETRIC EFFICIENCY

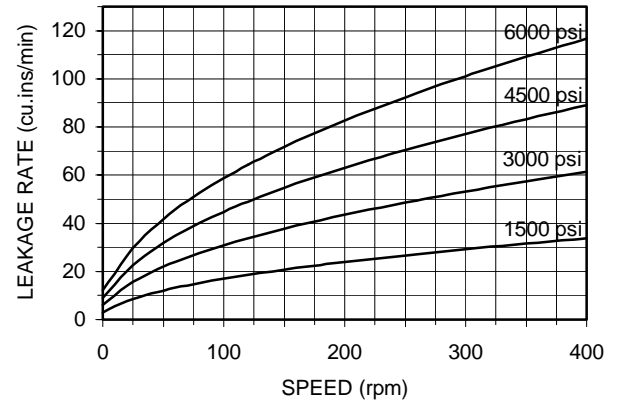

STARTING AND LOW SPEED TORQUE

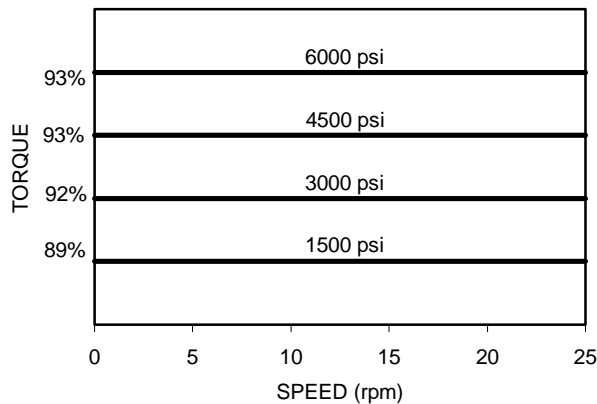

IDLING AND BOOST PRESSURE

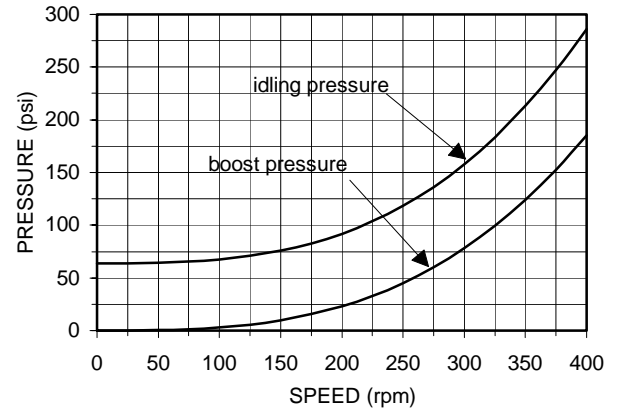

BEARING LIFETIME

The graph refers to the motor with the standard roller bearings. Note that the average lifetime of a bearing (B_{50} lifetime) is approximately 5 times the B_{10} lifetime.

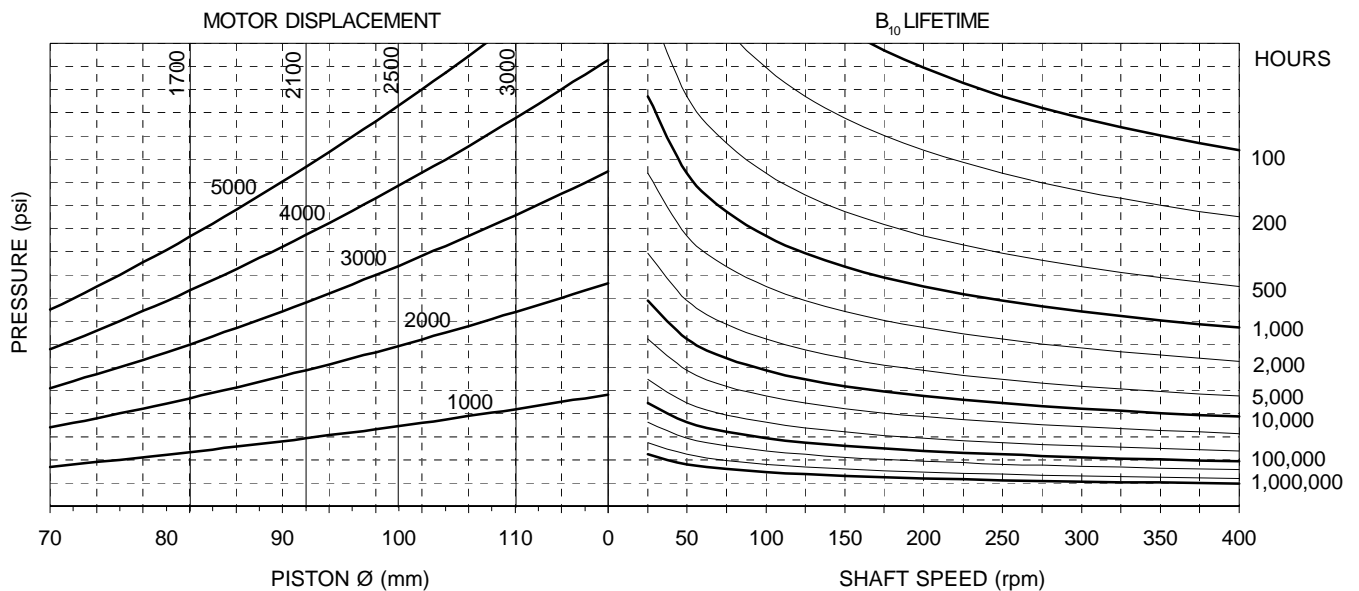

BEARING OPTIONS

Spherical roller bearings (Standard) - The lifetime of the standard bearings is given in the bearing lifetime graph.

Reinforced shaft and larger spherical roller bearings (option E) - the lifetime is 4.35 times the equivalent lifetime of standard bearings given in the graph. version.

Note:

The BS 3550 spline shaft is available both in the standard and the reinforced "E" versions.

The 65-3-20 DIN 5480 internal spline shaft is only available in the standard version.

The 80-2-25 DIN 5480 internal spline and the Parallel Keyed shafts are only available in the reinforced "E"

For longer lifetimes contact our technical department.

ORDER CODES

GM6	2100	1	-	-	D90	-	-	-
-----	------	---	---	---	-----	---	---	---

MOTOR CODE

1. **Nominal displacement** - See motor spec. table

2. **Shaft options:** 1 = Ext. BS 3550 (std)
 2 = Tapered
 8 = Parallel Keyed (only with "E" bearings)
 9 = Int. 65-3-20 DIN 5480 (only standard bearings)
 9 = Int. 80-3-25 DIN 5480 (only with "E" bearings)

3. **Bearings:** No code = Spherical roller bearings
 E = Reinforced version

4. **Other options:** HP = High pressure version only 1700, 2100
 U = Without shaft seal
 SV = Shaft seal protection
 VY = Viton seals
 I = Case press. relief valve 43psi

DISTRIBUTOR CODE See Page 46

5. **Distributor:** D90 standard

6. **Tachometer:** K = Predisposed for tachometer
 J = Mechanical Tach. mount
 JB2 = Mount for BEI encoder E25 BA (type 6R)
 JB4 = Mount for Hall Effect switch up to 200 pulses per rev.

ASSEMBLY CODES

7. **Direction of shaft rotation:** standard motors are supplied with clockwise rotation (viewed from shaft end) with flow in port A, out port B.
 No code = Clockwise rotation
 L = Counter-Clockwise rotation

8. **Distributor cover position:** See Page 7
 No code = Position DM1
 DM~ = Other position

DIMENSIONS

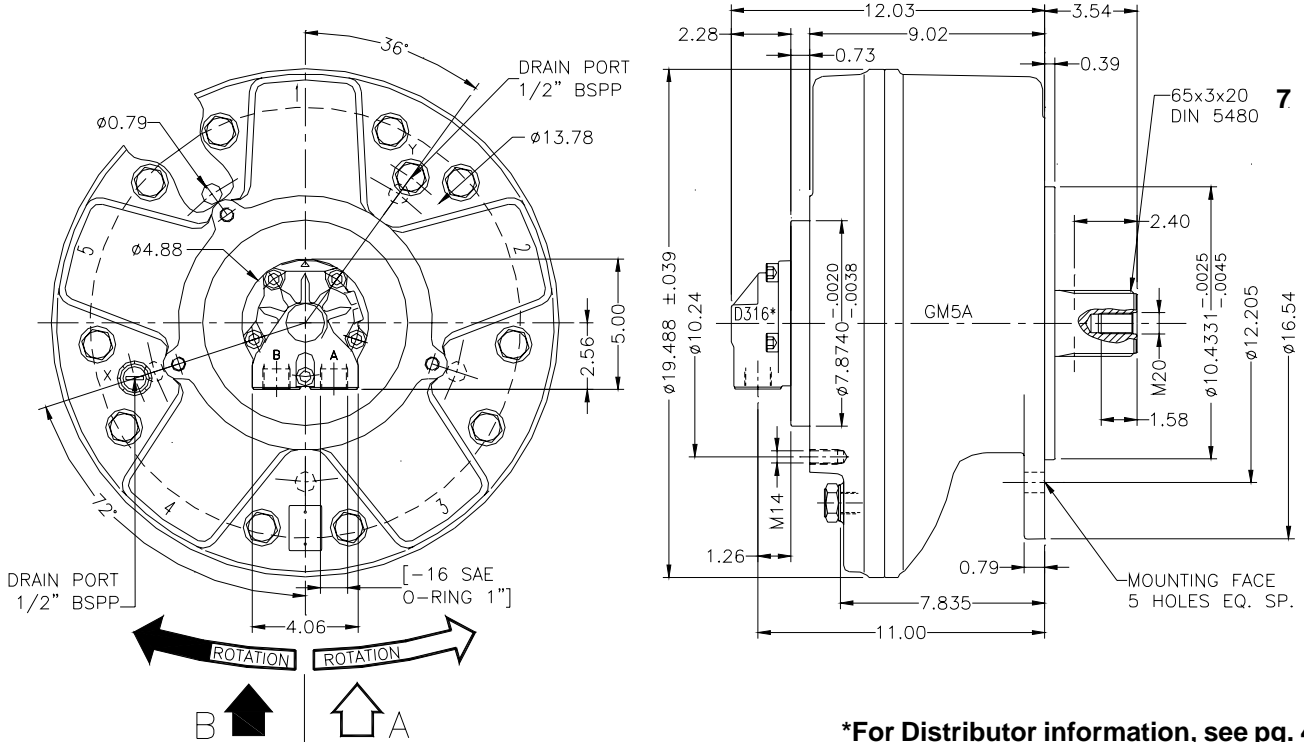

*For Distributor information, see pg. 46.

SHAFT OPTIONS

Splined DIN 5480 **7**
UNI 220 **1**

Tapered **2**

Parallel Keyed **8**

Internal DIN 5480 **9**
Spline DIN 5482 **3**

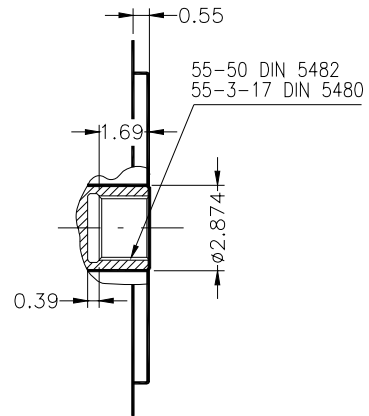
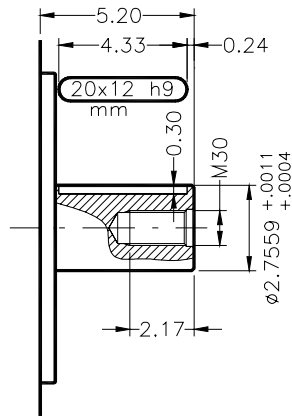
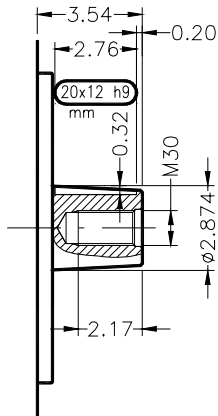
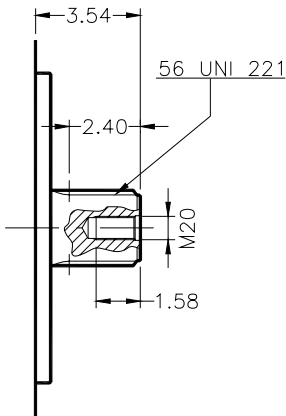

SPLINE DATA (dimensions in mm [1 in = 25.4 mm])

DIN	65-3-20 DIN 5480	55-2-26 DIN 5482	55-3-17 DIN 5480	56 UNI 221
	d0 Ø60.0	Ø52.0	Ø51.0	d1 Ø56.0 ^{+0.030} / ₊₀ H7
	d1 Ø65.0 ^{+0.740} / ₊₀ H14	Ø55.0 ^{+0.300} / ₊₀ H12	Ø55.0 ^{+0.740} / ₊₀ H14	d2 Ø65.0 ^{+0.190} / ₊₀ H11
	d2 Ø59.0 ^{+0.190} / ₊₀ H11	Ø50.0 ^{+0.160} / ₊₀ H11	Ø49.0 ^{+0.160} / ₊₀ H11	A 10.0 ^{+0.028} / _{+0.013} F7
	A Ø5.25	Ø3.5	Ø5.25	d3 Ø56.0 ^{-0.010} / _{-0.029} g6
	da Ø54.101 ^{+0.190} / ₊₀ H11	Ø46.902 ^{+0.100} / ₊₀ H10	Ø43.807 ^{+0.160} / ₊₀ H11	d4 Ø65.0 ^{-0.100} / _{-0.290} d11
	d3 Ø64.4 ⁻⁰ / _{-0.190} h11	Ø54.5 ⁻⁰ / _{-0.190} h11	Ø54.4 ⁻⁰ / _{-0.190} h11	B 10.0 ^{-0.013} / _{-0.028} f7
	d4 Ø58.4 ⁻⁰ / _{-0.740} h14	Ø49.0 ⁻⁰ / _{-0.300} h12	Ø48.4 ⁻⁰ / _{-0.620} h14	
	B Ø6.0	Ø3.5	Ø6.0	
	db Ø70.999 ^{-0.030} / _{-0.076} f8	Ø56.953 ^{-0.060} / _{-0.134} e9	Ø60.873 ^{-0.030} / _{-0.076} f8	

ADAPTOR

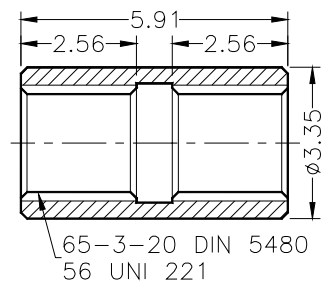

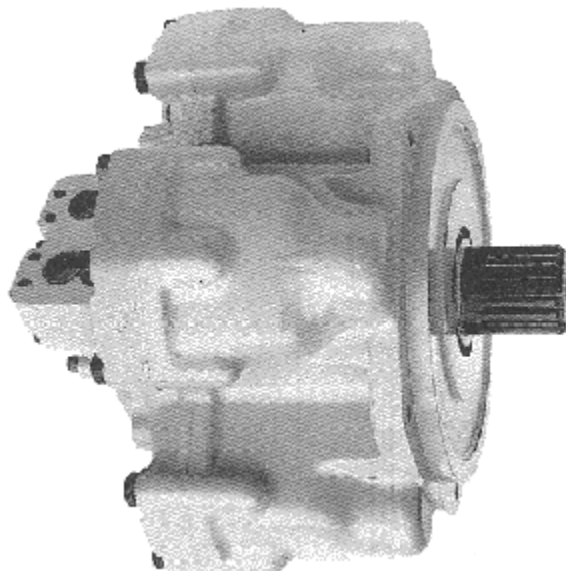

L7B		2000	2500	3000	3600	4300
Displacement	<i>in³/rev</i>	125.27	154.17	183.06	221.90	263.61
Specific torque	<i>lb.ft/100psi</i>	166.22	204.57	242.91	294.45	349.80
Cont. pressure	<i>psi</i>	3550	3550	3550	3550	3550
Peak pressure	<i>psi</i>	6000	6000	6000	6000	6000
Max. speed	<i>rpm</i>	280	260	220	200	170
Peak power	<i>HP</i>	147	174	202	255	295

Approximate weight: 638 lbs

Motor casing oil capacity: 5.6 gallons

Max. casing pressure: 14 psi continuous
70 psi peak

DIMENSIONS

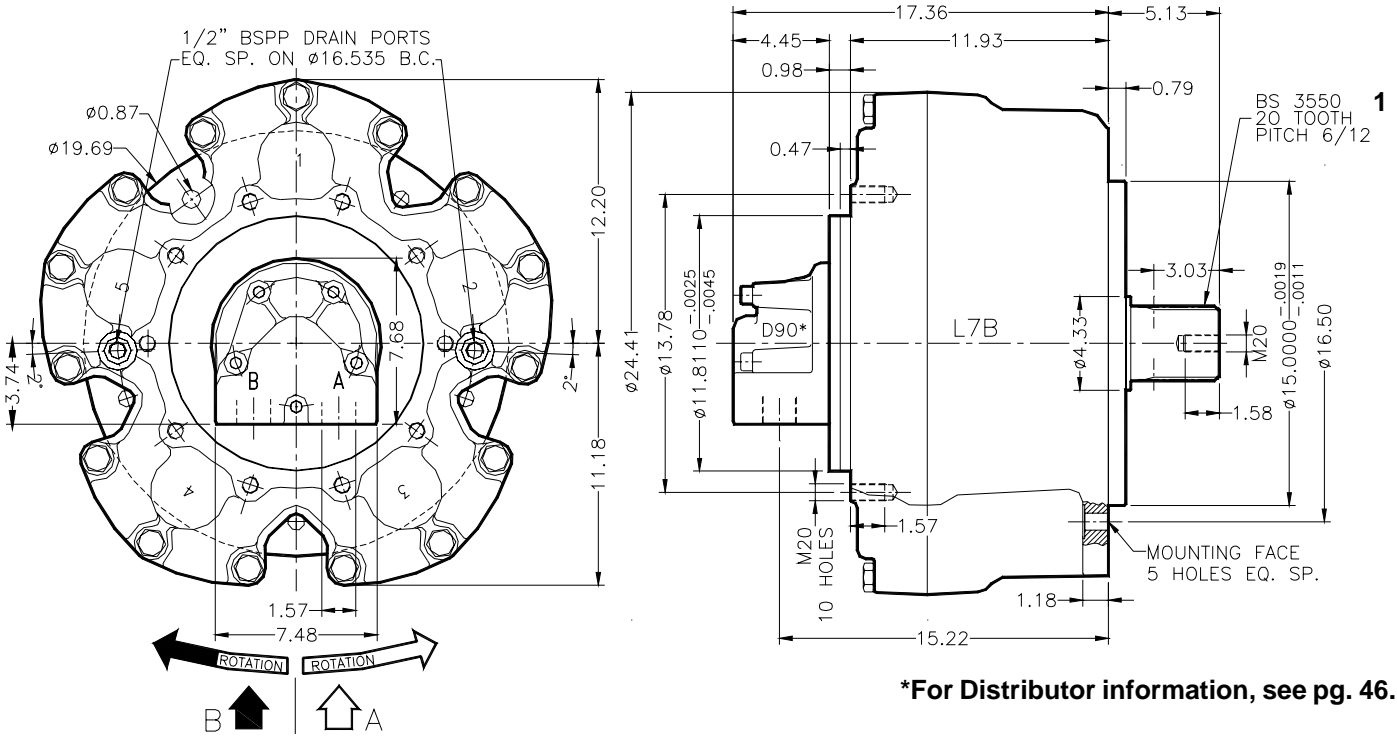

SHAFT OPTIONS

Splined BS 3550 1
DIN 5480 7

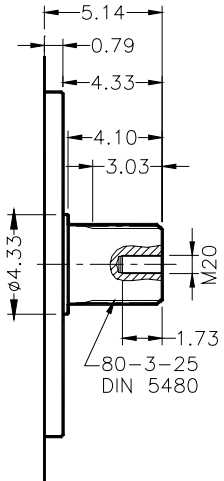

Tapered 2

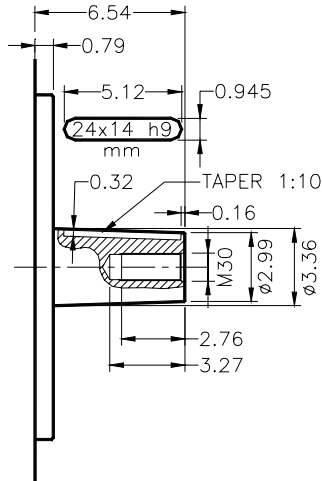

Parallel Keyed 8

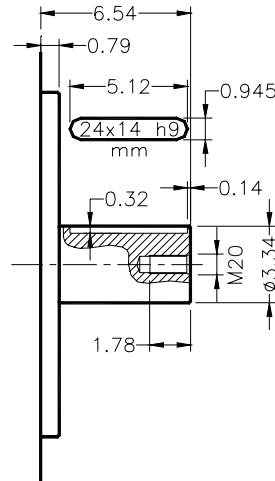

Internal DIN 5480 9
Spline

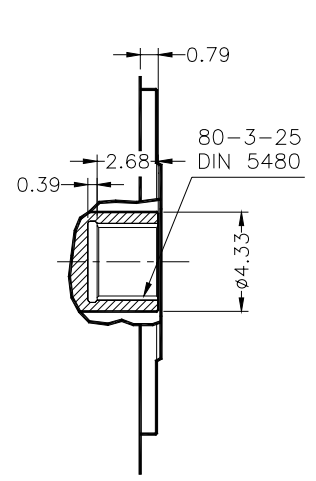

SPLINE DATA (dimensions in mm [1 in = 25.4 mm])

BS 3550 Pitch 6/12	
A	$\phi 88.0_{-0.17}^{+0.047}$
B	$\phi 84.66$
C	$\phi 80.0_{-0.070}^{+0.480}$
D	$\phi 97.0_{+0.030}^{+0.082}$
E	$\phi 8.12$

80-3-25 DIN 5480	
d0	$\phi 75.0$
d1	$\phi 80.0_{+0}^{+0.740}$ H14
d2	$\phi 74.0_{+0}^{+0.190}$ H11
A	$\phi 5.25$
dA	$\phi 68.9_{+0}^{+0.740}$ H9
d3	$\phi 79.4_{-0.190}^{+0}$ h11
d4	$\phi 73.4_{-0.740}^{+0}$ h14
B	$\phi 6.00$
dB	$\phi 85.9_{-0.090}^{+0.036}$ f8

ADAPTOR

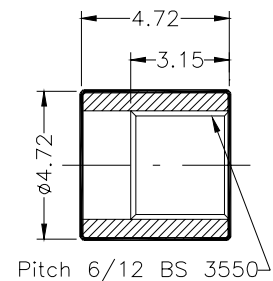

PERFORMANCE The graphs indicate the typical performance characteristics of the L7B-3000 motor operating with mineral oil with viscosity 40 cSt at 122°F.

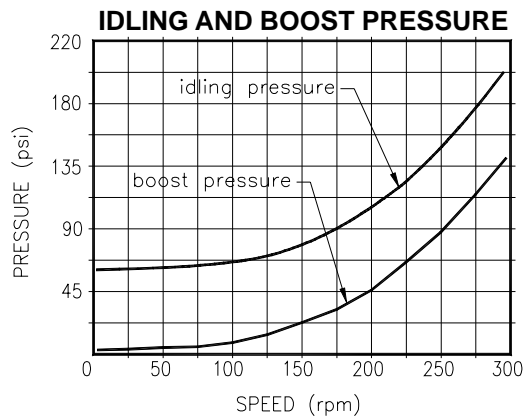
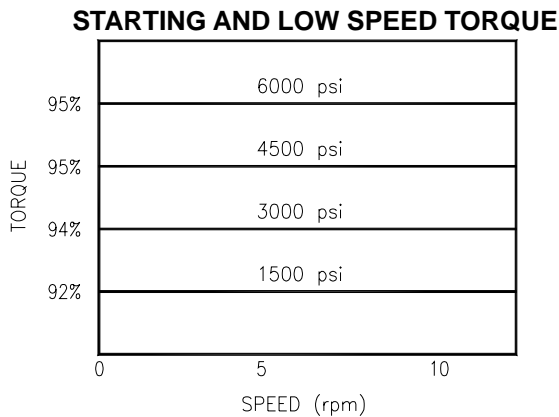
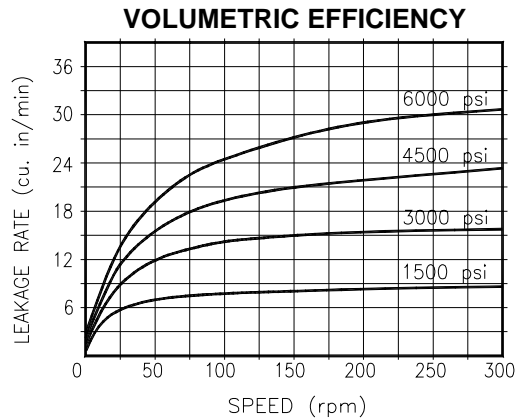
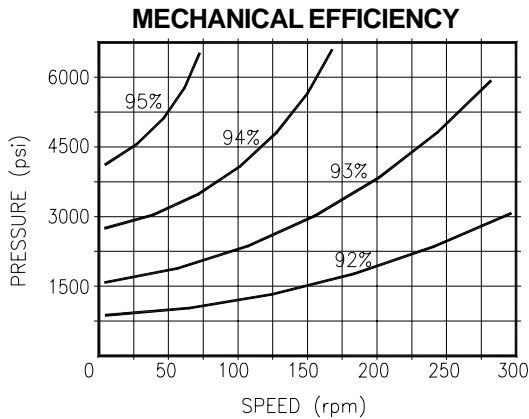

BEARING LIFETIME The graph refers to the motor with the standard roller bearings. Note that the average lifetime of a bearing (B_{50} lifetime) is approximately 5 times the B_{10} lifetime.

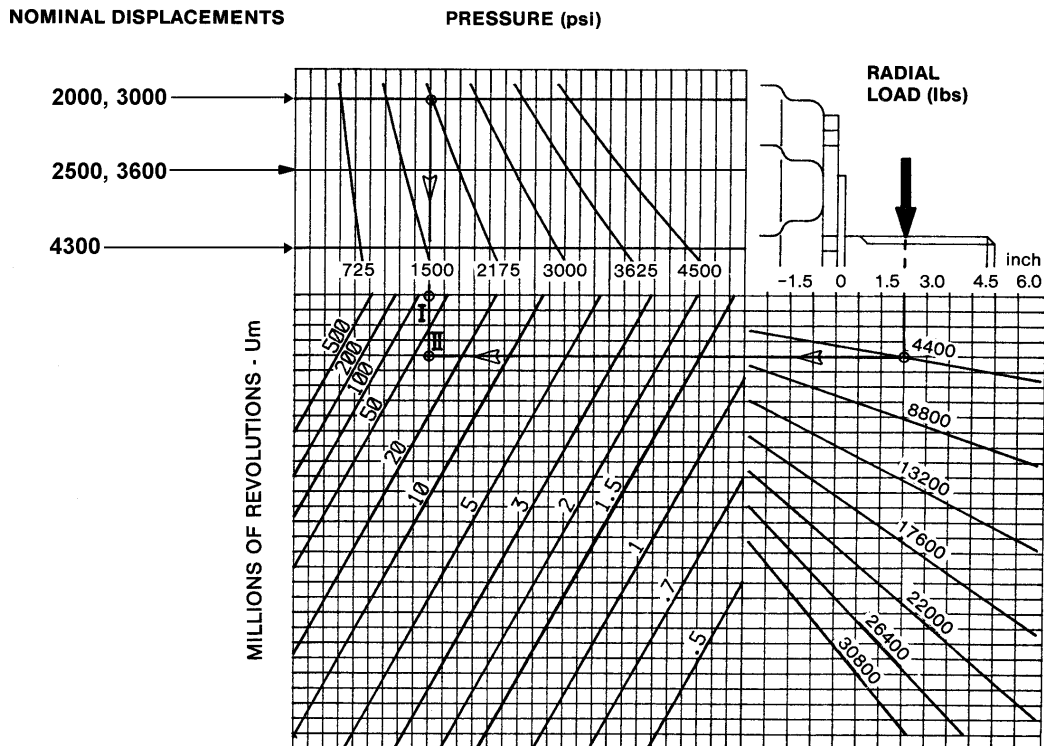

BEARING OPTIONS

Spherical roller bearings (Standard) - The lifetime of the standard bearings is given in the bearing lifetime graph.

For longer lifetimes contact our technical department.

Reinforced shaft and larger spherical roller bearings (option E) - the lifetime is 4.35 times the equivalent lifetime of standard bearings given in the graph. version.

ORDER CODES

L7B	3000	1	-	-	D90	-	-	-
-----	------	---	---	---	-----	---	---	---

MOTOR CODE

1. **Nominal displacement** - See motor spec. table

2. **Shaft options:**

- 1 = BS 3550 (standard)
- 2 = Tapered
- 7 = Ext. 80-3-25 DIN 5480
- 8 = Parallel Keyed
- 9 = Int. 80-3-25 DIN 5480

3. **Bearings:** No code = Spherical roller bearings
E = Reinforced version

4. **Other options:**

- U = Without shaft seal
- I = Case press. relief valve 43psi

DISTRIBUTOR CODE See Page 46

5. **Distributor:** D90 standard

6. **Tachometer:** K = Predisposed for tachometer
J = Mechanical Tach. mount
JB2 = Mount for BEI encoder
E25 BA (type 6R)
JB4 = Mount for Hall Effect switch
up to 200 pulses per rev.

ASSEMBLY CODES

7. **Direction of shaft rotation:** standard motors are supplied with clockwise rotation (viewed from shaft end) with flow in port A, out port B.

- No code = Clockwise rotation
- L = Counter-Clockwise rotation

8. **Distributor cover position:** See Page 7

- No code = Position DM1
- DM~ = Other position

GR 100/200



Note: The GR Series replaces the PR Series

SPECIFICATION DATA

GR 100R / GR 100W

NOM DISP.	MOTOR GM05 DISP. CU/IN	RESULT DISP. CU/IN	TORQUE 100/psi FT/LB	MAX PRESSURE		MAX TORQUE FT/LB
				CONT.	PEAK	
14	3.62	14.90*	19.77	3000	4000	1800
18	4.54	18.72*	24.84	3000	4000	1800
29	7.06	29.12*	38.60	3000	4000	1800
32	7.91	32.62*	43.28	3000	4000	1800
38	9.26	38.18*	50.60	3000	3750	1800
41	10.18	41.99*	55.71	2750	3000	1800
48	11.72	48.34*	64.14	2500	2750	1800
52	10.18	52.60**	69.79	2250	2250	1800

GR 200R / GR 200W

NOM DISP.	MOTOR GM05 DISP. CU/IN	RESULT DISP. CU/IN	TORQUE 100/psi FT/LB	MAX PRESSURE		MAX TORQUE FT/LB
				CONT.	PEAK	
14	3.62	14.90*	19.77	3000	5000	2400
18	4.54	18.72*	24.84	3000	5000	2400
29	7.06	29.12*	38.60	3000	5000	2400
32	7.91	32.62*	43.28	3000	5000	2400
38	9.26	38.18*	50.60	3000	4500	2400
41	10.18	41.99*	55.71	3000	4000	2400
48	11.72	48.34*	64.14	3000	3750	2400
52	10.18	52.60**	69.79	3000	3500	2400
60	11.72	60.55**	80.35	2500	3000	2400

GR 200R / GR 200W

NOM DISP.	MOTOR GM1 DISP. CU/IN	RESULT DISP. CU/IN	TORQUE 100/psi FT/LB	MAX PRESSURE		MAX TORQUE FT/LB
				CONT.	PEAK	
43	10.55	43.51*	57.73	3000	3500	2400
50	12.33	50.86*	67.48	3000	3500	2400
61	14.91	61.50*	81.60	2500	3000	2400
73	17.79	73.38*	96.86	2000	2500	2400

* RATIO 4.125

** RATIO 5.167

PERFORMANCE DATA

GR 100-200R / GR 100-200W

FLOW (GPM)	1	2	4	8	12	16	20	24	28	32	36
DISP.	RPM IN RELATION TO ABOVE FLOW (GPM)										
14.9	15	30	60	120	180	240	300	360			
18.72	12	24	48	96	144	192	240	288	336		
29.12	7.5	15.5	31	62	93	124	155	186	217	248	280
32.62	7	14	28	56	84	112	140	168	196	224	252
38.18	6	12	24	48	71	95	119	143	167	191	215
41.99	5	10	21	43	64	86	108	129	151	173	195
48.34	4.5	9	18	38	56	75	94	113	132	151	170
52.60	4.3	8.5	17	34	52	69	87	100	121	139	156

GR 200R / GR 200W

FLOW (GPM)	1	2	4	8	12	16	20	24	28	32	36
DISP.	RPM IN RELATION TO ABOVE FLOW (GPM)										
43.51	5	10	21	42	63	84	105	126	147	169	189
50.86	4.5	9	18	36	54	72	90	118	126	143	162
61.50	3.5	7.5	14.5	29	44	59	73	89	104	119	133
73.38	3	6	12	25	37	40	62	74	87	100	112

MAX. FLOW AND PRESSURE MUST NOT OCCUR SIMULTANEOUSLY. REFER TO LIFE CHART FOR B10 LIFE.

DIMENSIONS AND MOUNTING DATA
GR 100R-200R / GM05 / GM1 / BRAKE
SAE 'C' FLANGE MOUNT

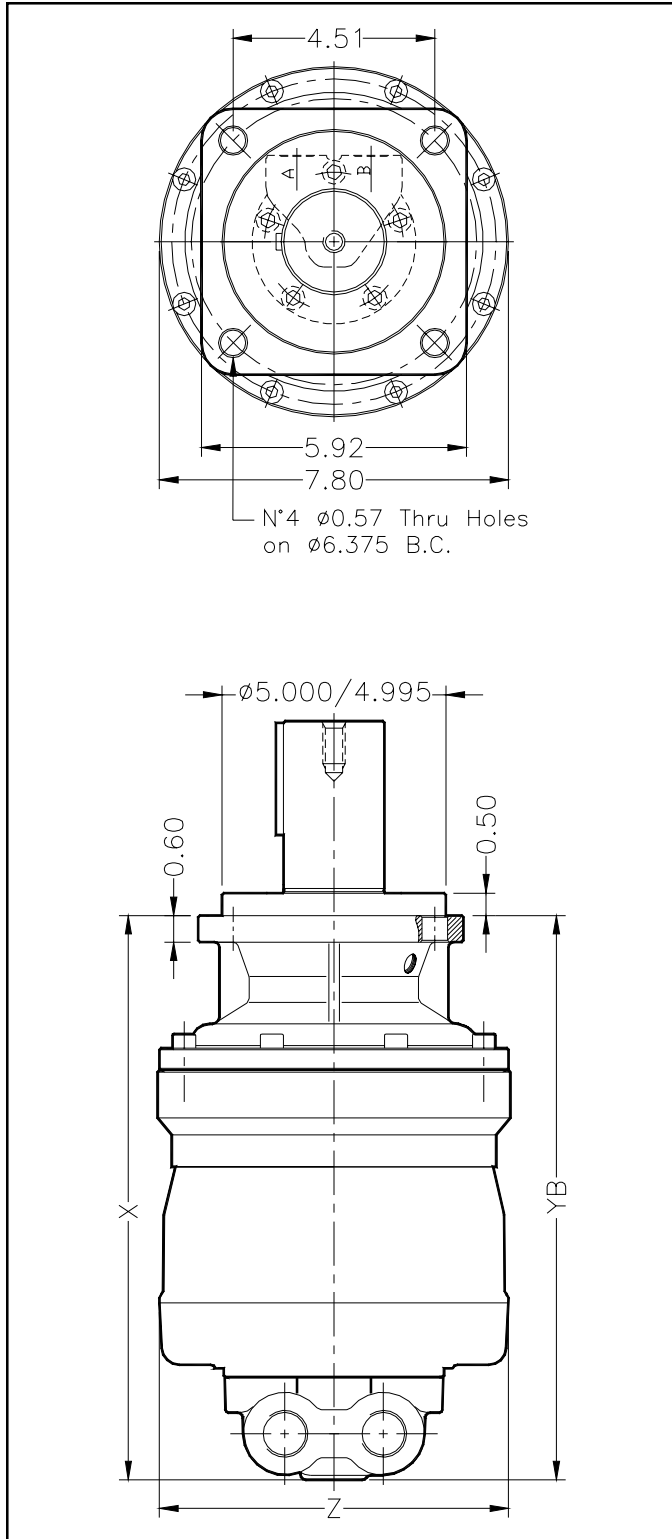

TYPE	DISP	X	YB BRAKE		Z	GR... WGT
			DB80	DB82		
GR100-GM05	All	12.08	16.60	18.22	8.07	55 lbs
GR200-GM05	All	12.56	16.60	18.22	8.07	64 lbs
GR200-GM1	All	13.36	17.43	19.05	9.53	80 lbs

DIMENSIONS AND MOUNTING DATA
GR 200W WHEEL MOTOR

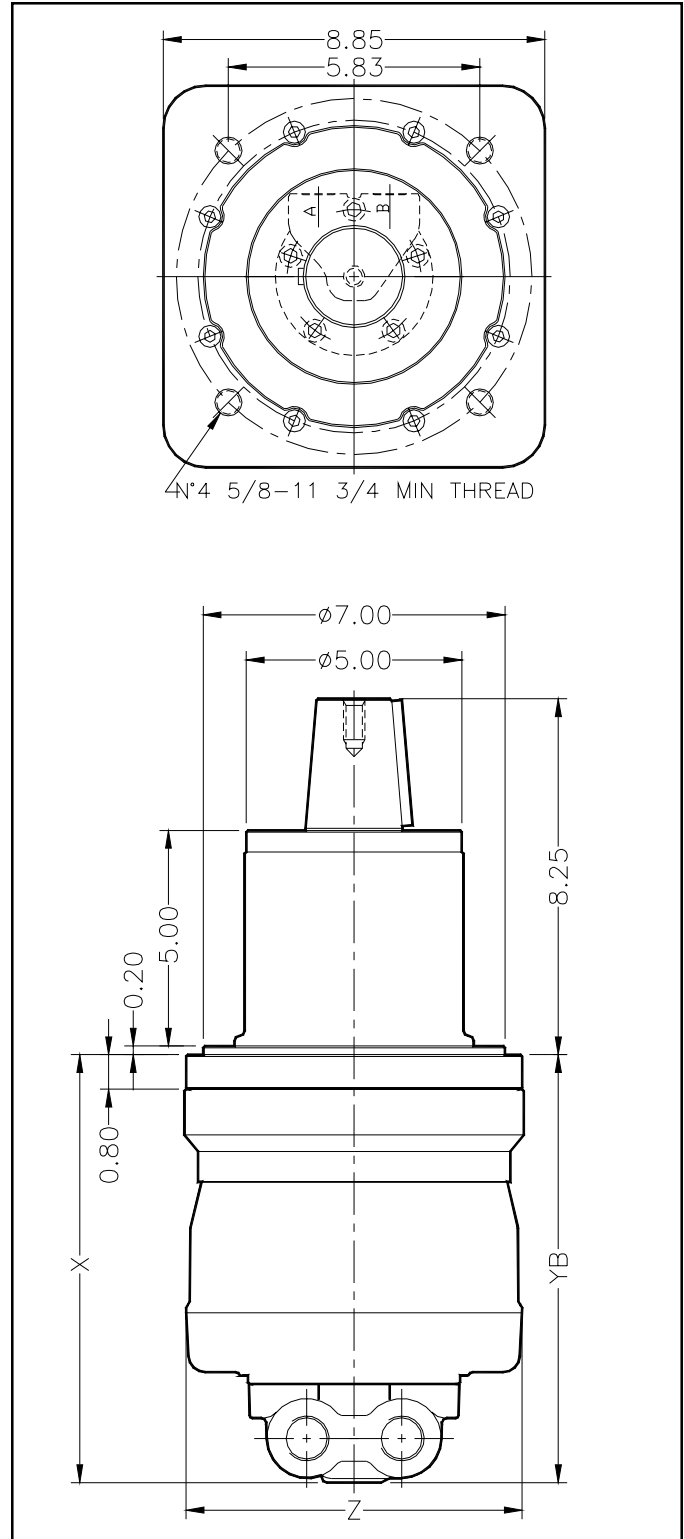

TYPE	DISP	X	YB BRAKE		Z	GR... WGT
			DB80	DB82		
GR200-GM05	All	9.95	13.83	15.55	8.07	75 lbs
GR200-GM1	All	10.75	14.63	16.35	9.53	90 lbs

SHAFT OPTIONS - GR 100

1 1/2" Straight Key

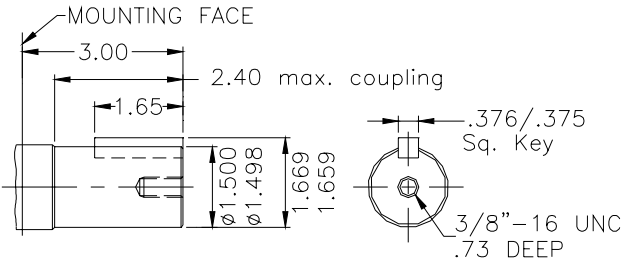

1 1/2" Splined

External Involute Spline, 12/24 DP
17 Tooth 30° P.A., Flat Root
Side Fit per ANSI B92.1, 1976

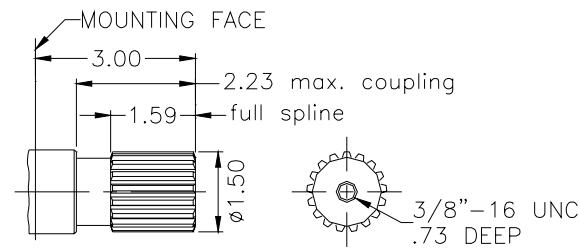

SHAFT OPTIONS - GR 200

2 1/4" Straight Key

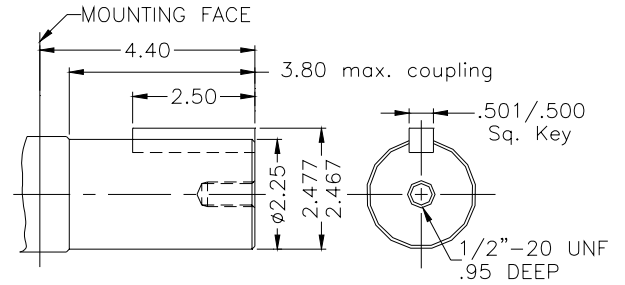

2 1/8" Splined

External Involute Spline, 8/16 DP
16 Tooth 30° P.A., Flat Root
Side Fit per ANSI B92.1, 1976

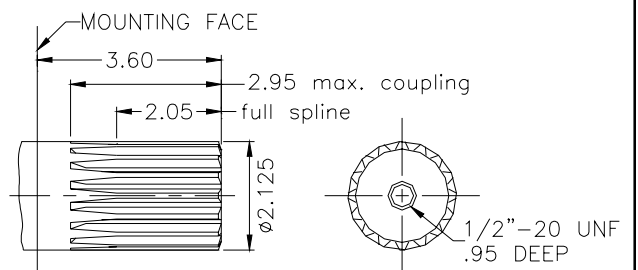

2 1/4" Tapered Key

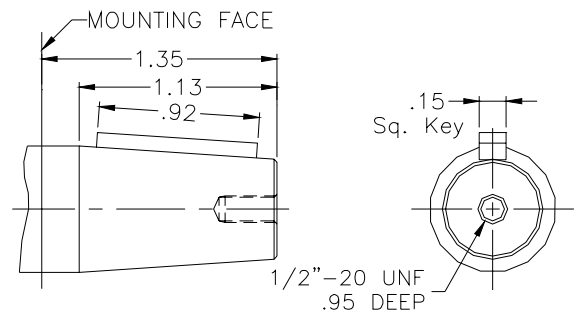

DB SERIES BRAKES

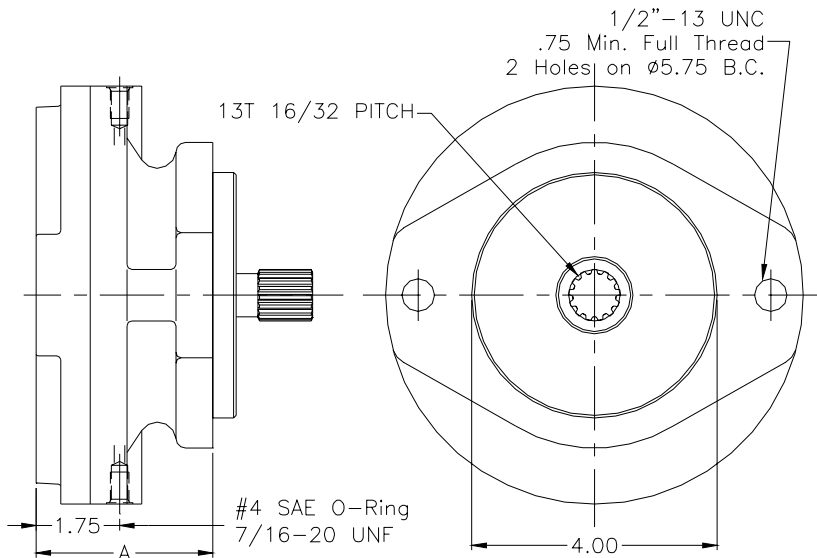

DIMENSIONS/TORQUE RATINGS

MODEL	DB 80	DB 82
A	2.88	4.50
Release Pressure (PSI)	150/66 220/100	185/83 295/133
Torque (LB-FT)	370/175	370/400
Max. Brake Pressure (PSI)	3000	4000
Weight	20 LBS.	25 LBS.

PERFORMANCE

MECHANICAL EFFICIENCY

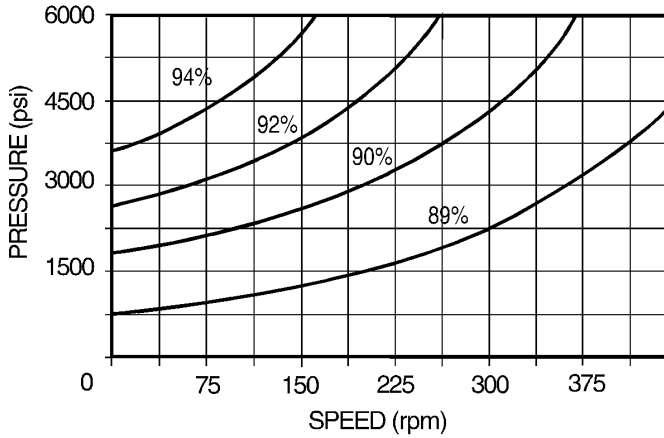

VOLUMETRIC EFFICIENCY

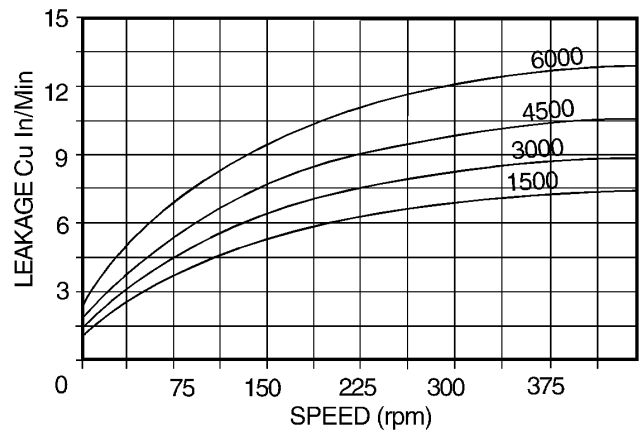

STARTING & LOW SPEED TORQUE

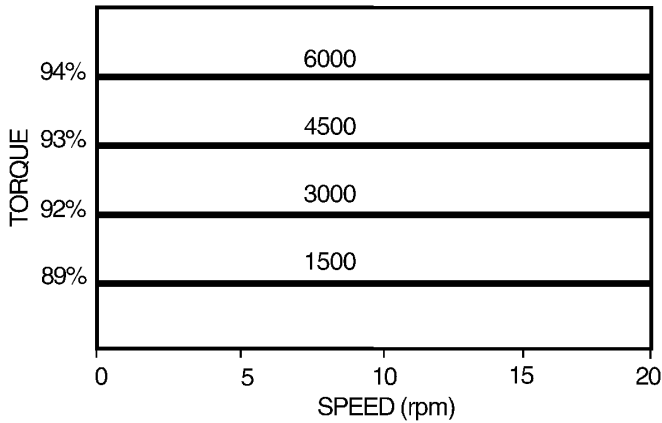

IDLING & BOOST PRESSURES

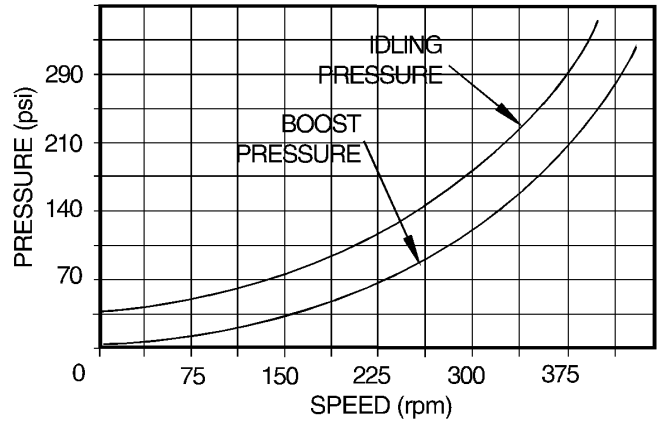

BEARING LIFETIME

The graph refers to the motor with the optional roller bearings (option H) recommended for most applications.

Note that the average lifetime of a bearing (B_{50} lifetime) is approximately 5 times the B_{10} lifetime.

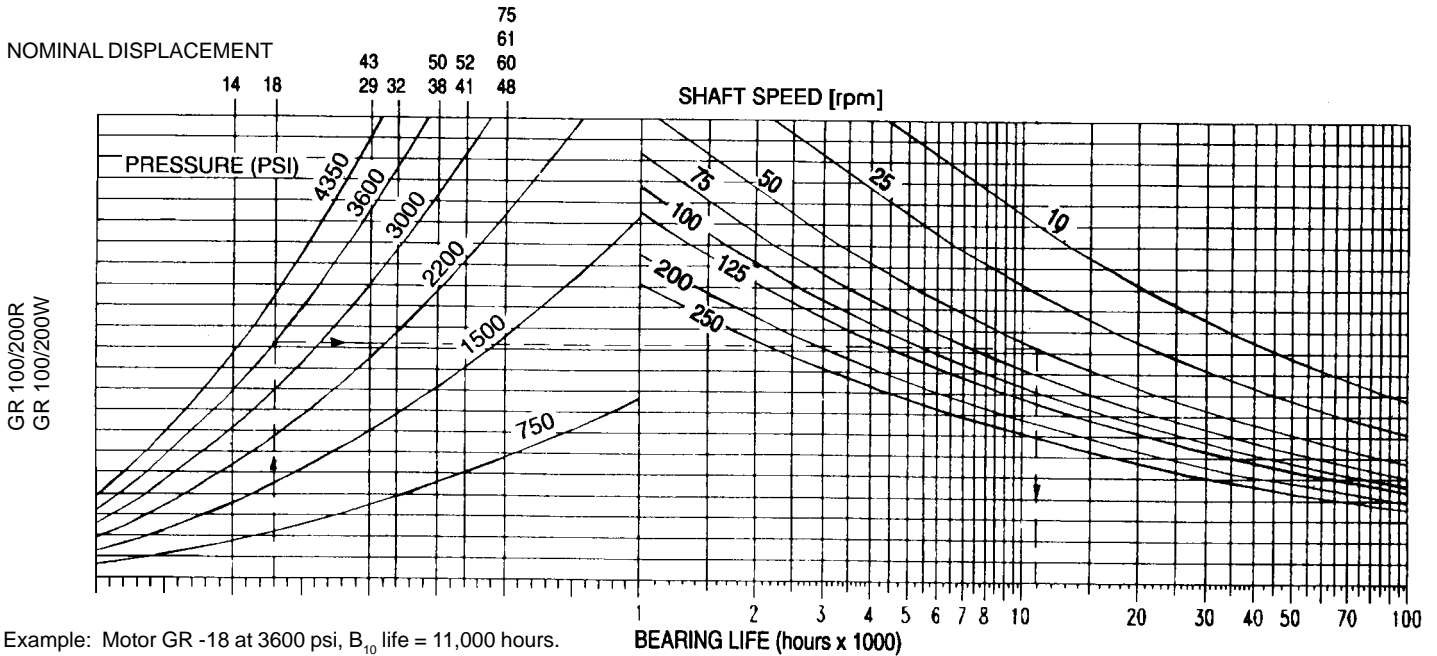

Example: Motor GR -18 at 3600 psi, B_{10} life = 11,000 hours.

ORDER CODES

GR	10	4	05	-	X	-	D36	-	-
----	----	---	----	---	---	---	-----	---	---

MOTOR CODE

1. Motor Gearbox Assembly:

GR - Standard
GRW - Wheel Motor

2. Series code: 100R - 10
200R - 20

3. Ratio code: Ratio without decimals

4. Motor series: GM05- 05
GM1- 1

5. Nominal displacement:
See motor spec. table

6. Shaft options: C = Straight Keyed
X = Ext. Splined
K = Taper Keyed

7. Brake options: DB80
DB82
- = No brake

8. Distributor: See Page 46

9. Shaft seal options:
O = Separate oil
E = Common oil

10. Tachometer: K = Predisposed for tacho.
J = Mechanical Tach. mount
JB2 = Mount for BEI Encoder
E25 BA (type 6R)
JB4 = Mount for Hall Effect
switch up to 200 pulses
per rev.



Possible motor-distributor combinations

	GM05	GM1	GM2	GM3	GM4	GM5	GM6	L7
D3.. , D4...	•	•	•	•	•	•	-	-
D90	-	-	-	-	‡	‡	•	•
D250	-	-	-	-	-	-	‡	‡

- ALWAYS POSSIBLE
- ‡ POSSIBLE ON REQUEST
- NOT AVAILABLE

D36 is the standard distributor for GM05 & GM1.
 D316 is the standard distributor for GM2, GM3, GM4 & GM5 series.
 D90 is standard for GM6 & L7 series.

For applications with frequent pressure peaks or severe vibrations, distributors with a steel anti-extrusion ring for the main seal are recommended; available on request.

Special distributors can be supplied that ensure silent running over a wide range of pressure and speed values.

NB: the purge valve in distributors D481, D491, D311 discharge 5.3 gal/min at 285 psi: adequate provision should be provided to protect the charge pump.

Distributors



			D4.. HS	D3.. LS	D30 LS	D90 HS	D250 HS
Speed	<i>rpm</i>	cont. max.	1200 2400	300 500	300 500	700 1200	500 1000
Pressure	<i>psi</i>	cont. max.	3550 7100	3550 7100	2000 4000	3550 7100	3550 7100
Flow	<i>gal(US)/min</i>	cont. max.	53 106	53 106	53 106	132 264	264 528

	PORTS	HS/LS	DESCRIPTION
D30A	3/4" BSP (A)	LS	Short distributor
D31A	3/4" BSP (R)	LS	
D36A	3/4" SAE (R)	LS	Standard for GM05, GM1 series
D310A	1" BSP (R)	LS	
D316A	1" SAE (R)	LS	Standard for GM2, GM3, GM3A, GM4, GM5A series
D311A	1" BSP (R)	LS	With purge valve 5.3 gal/min at 285 psi
D317A	1" SAE (R)	LS	With purge valve 5.3 gal/min at 285 psi
D312A	3/4" BSP (R)	LS	With purge valve 5.3 gal/min at 285 psi
D313A	1" BSP (R)	LS	With shuttle valve
D314A	1" SAE (R)	LS	With anti-cavitation valve
D315A	3/4" BSP (R)	LS	With shuttle valve
D37A	1" SAE 3000 psi (R)	LS	
D40A	1" BSP (R)	HS	For applications that require high speed & back pressure
D416A	1" SAE (R)	HS	For applications that require high speed & back pressure
D47A	1" SAE 3000 psi (R)	HS	
D48A	1" BSP (R)	HS	With double pressure relief valves, 6000 psi, 40 gal/min
D481A	1" BSP (R)	HS	As D48, with purge valve 5.3 gal/min at 285 psi
D49A	1" BSP (R)	HS	With double pressure relief valves, 3000 psi, 20 gal/min
D491A	1" BSP (R)	HS	As D49, with purge valve 5.3 gal/min at 285 psi
D90A	1.5" SAE 6000 psi (R)	HS	Standard for GM6 & L7 series
D250A	2" SAE 6000 psi (R)	HS	High capacity distributor

HS = high speed
 LS = low speed
 (A) = axial ports
 (R) = radial ports

Note: D42 substituted by D312(HS)
 D421 substituted by D313(HS)
 D422 substituted by D314(HS)

D30A

Light distributor with axial port connections.
 NB: Cont. press. 2000 psi; peak pressure 4000 psi.

Weight: 5.5 lbs

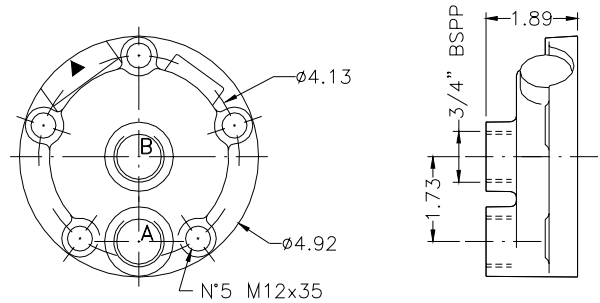

D31A

Distributor with 3/4" BSP ports.

D36A

Distributor with -12 SAE O-Ring 3/4" ports.

D310A

Distributor with 1" BSP ports.

D316A

Distributor with -16 SAE O-Ring 1" ports.

Weight: 8 lbs

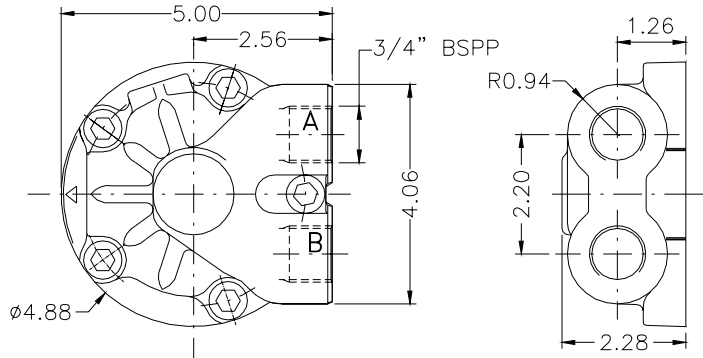

D311A

Distributor with low pressure purge valve. Max flow 5.3 gal/min at 285psi.

D317A

Same as D311 but with -16 SAE O-Ring 1" ports.

D312A

As D311, with -12 SAE O-Ring 3/4" ports.

Weight: 9.9 lbs

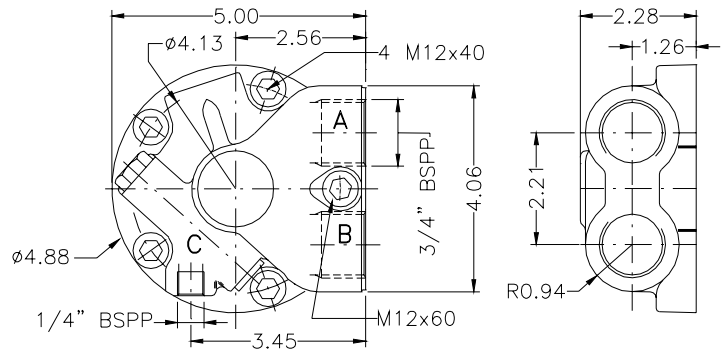
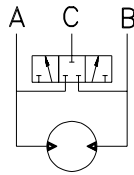

D313A

Distributor with shuttle valve for high pressure pilot

D315A

Same as D313 but with -16 SAE O-Ring 1" ports.

Weight: 9.9 lbs

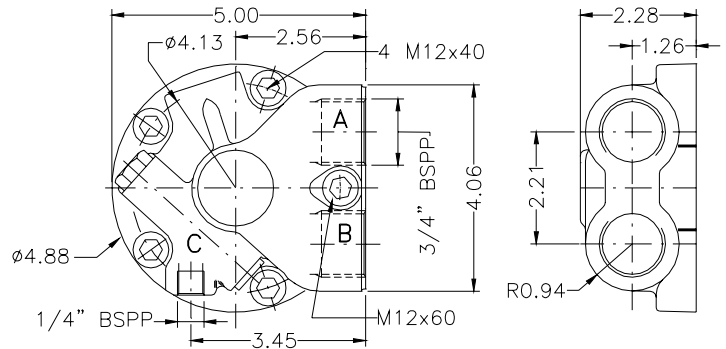
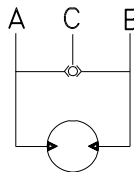

D314A

Distributor with anti-cavitation valve

Weight: 9.9 lbs

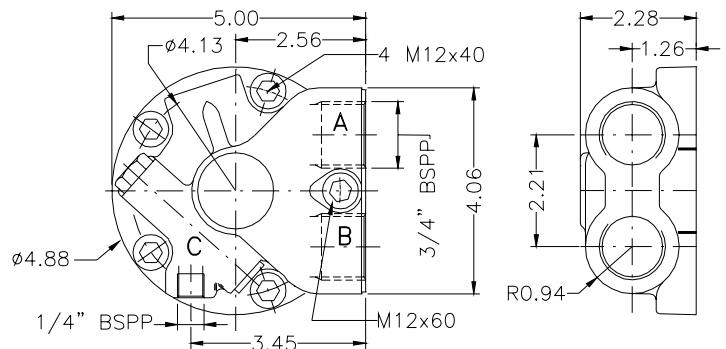
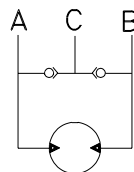

Distributors



D37A

Distributor with 1" SAE, 3000 psi flanges

Weight: 11 lbs

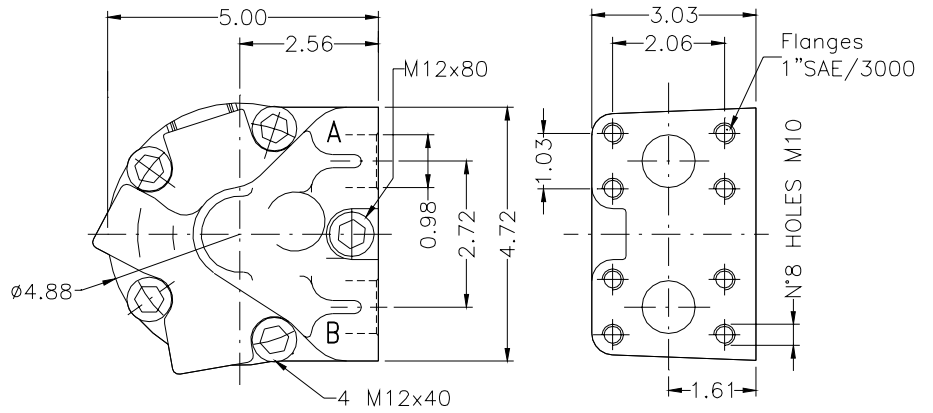

D40A

Distributor with 1" BSP ports.

D416A

Distributor with -16 SAE O-Ring 1" ports.

Weight: 11 lbs

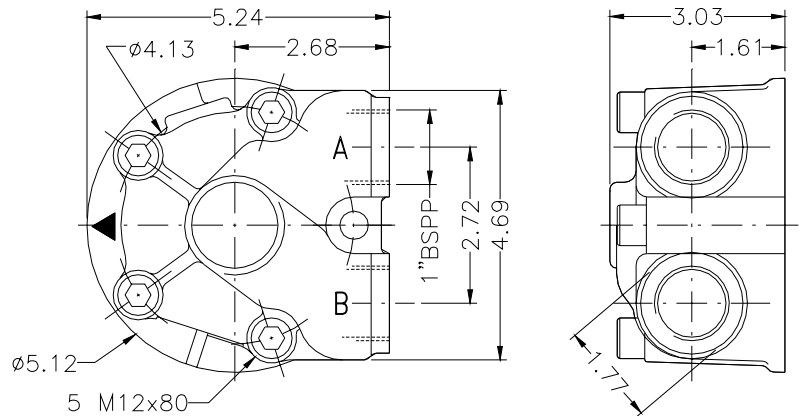

D47A

Distributor with 1" SAE, 3000 psi flanges

Weight: 13 lbs

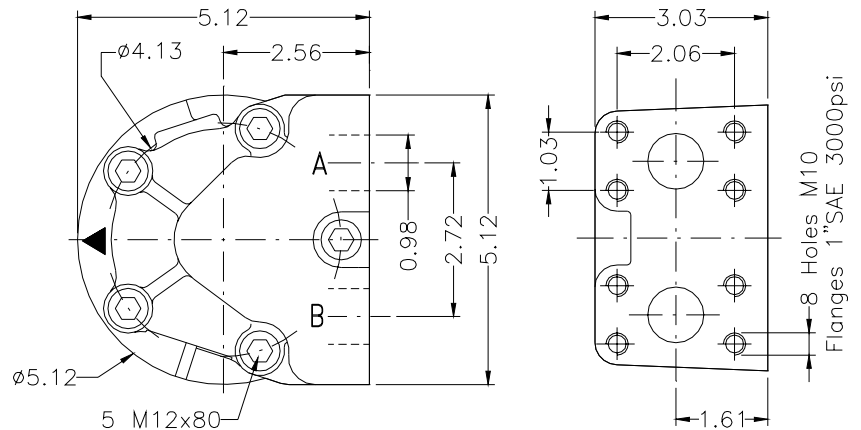

D48A

Distributor with direct acting relief valves. Variable pressure settings, max. 6000 psi. Max flow 50 gpm.

D481A

Same as D48A, but with purge valves (C port).

Weight: 13 lbs

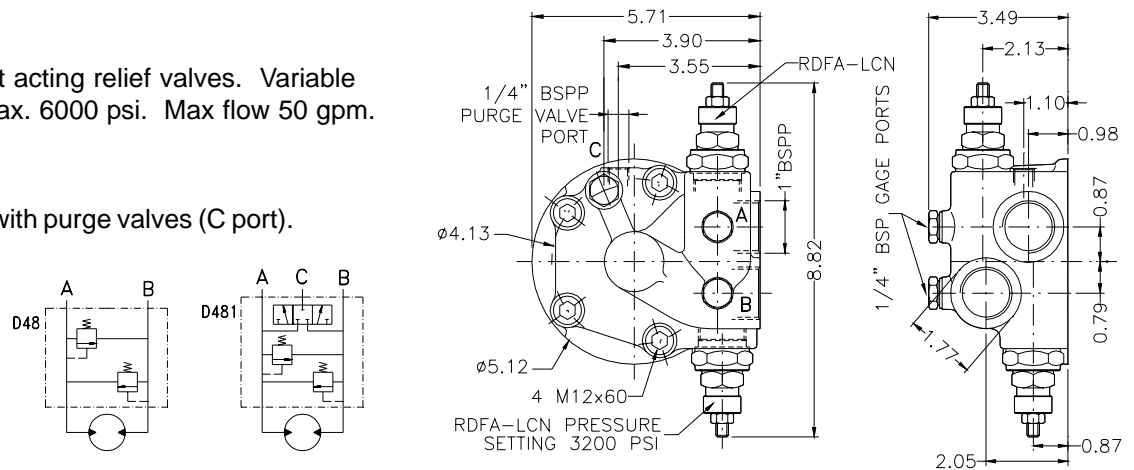

D49A

Distributor with double sliding spool pressure relief valves. Variable pressure settings, max 3000 psi, max flow 20 gal/min.

D491A

Same as D49, but with purge valves (C port), 5.3 gal/min. at 285 psi.

Weight: 13 lbs

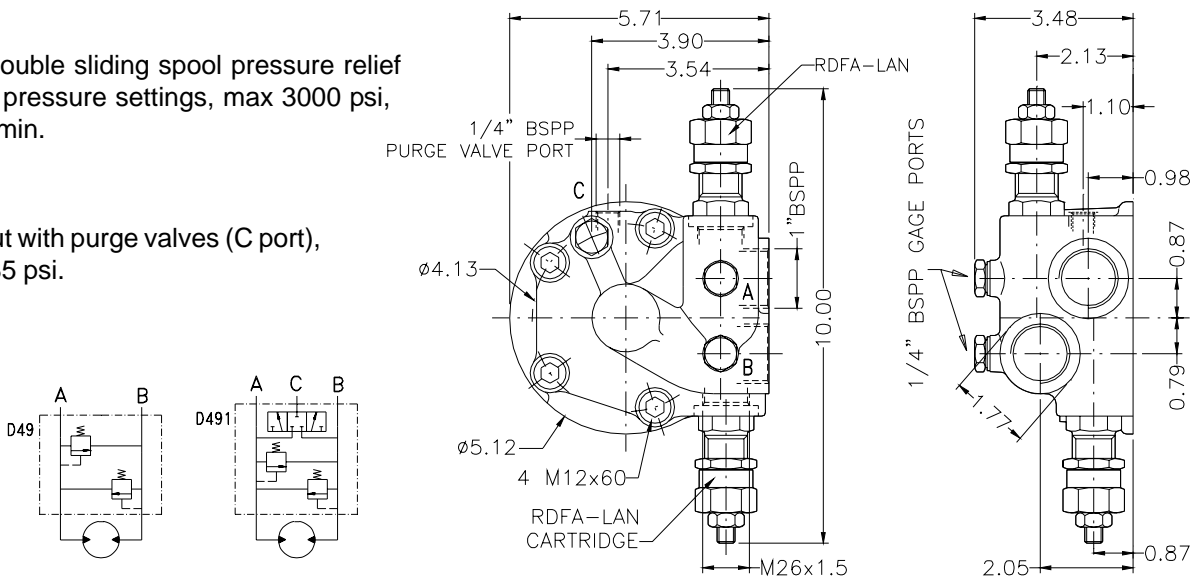

D90A

Standard distributor for GM6 Series Motors.

Weight: 32 lbs

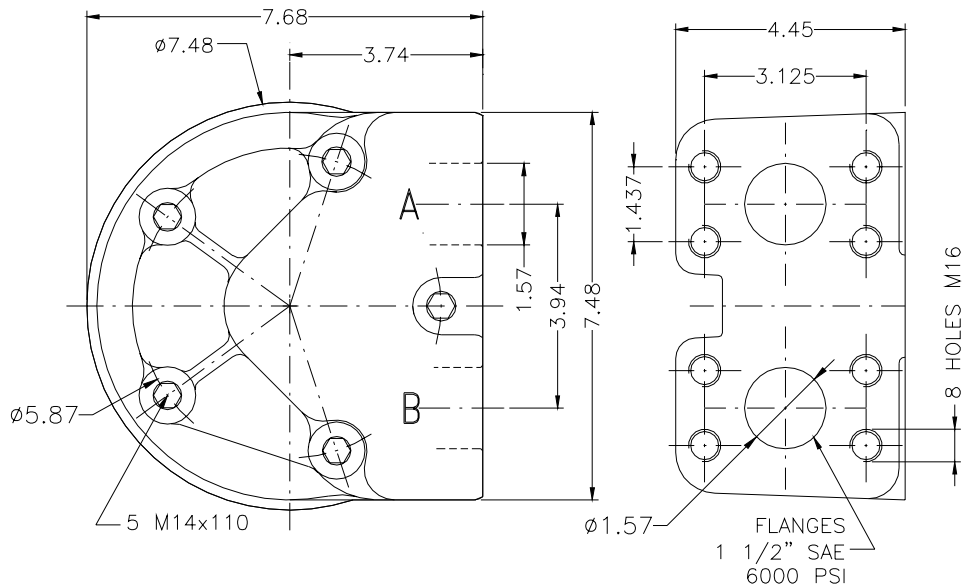

D250A

High flow distributor.

Weight: 110 lbs

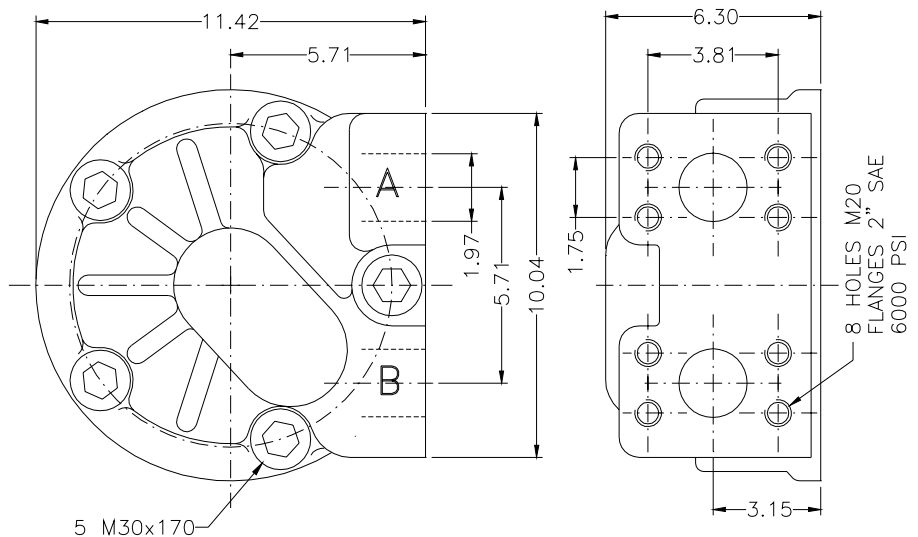

MECHANICAL TACHOMETER

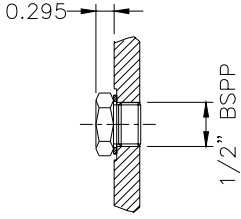
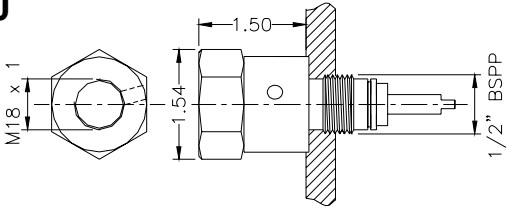
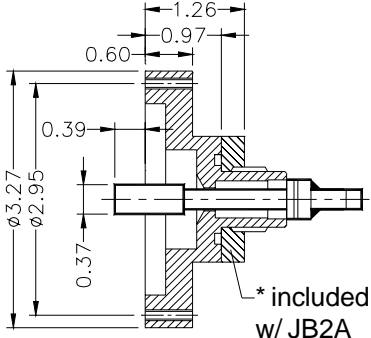
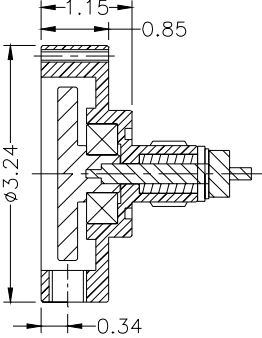
<p>Tachometer drive plug</p> <p>Code K</p> 	<p>Tachometer drive</p> <p>Code J</p> 
<p>Tach Drive Mount for BEI Encoder E25 BA (type 6R) on request</p> <p>Code JB2A* * use w/ D3... only</p> <p>Code JB2 use w/ all other distributors</p> 	<p>Tach Drive Mount for Hall Effect Switch on request</p> <p>Code JB4</p> 

High speed option for low speed distributors: D3.. (HS)

Low speed (LS) distributors such as D30, D31 ... D37 can be supplied mounted on a bronze disc (see figure). With this disc these distributors have the same max speed characteristics as high speed distributors (HS).

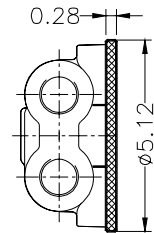

ORDER CODES

DESCRIPTION	CODE	
(7) DISTRIBUTOR TYPE	D ...	
(8) Valve pressure setting (bar)	(...)	
(9) Predisposed for tachometer Mechanical Tach. mount Mount for BEI encoder E25 BA (type 6R) Mount for Hall Effect switch up to 200 pulses per rev.	K J JB2/JB2A JB4	

Available on request:

- Standard distributors are supplied with a steel anti-extrusion ring for the main seal in the rotor which is suitable for high pressure operation.
- Special distributor for silent running motors
- Intermediate bronze disc for high speed operation with low speed distributors

GM05 SAE 'B' 2 BOLT FLANGE

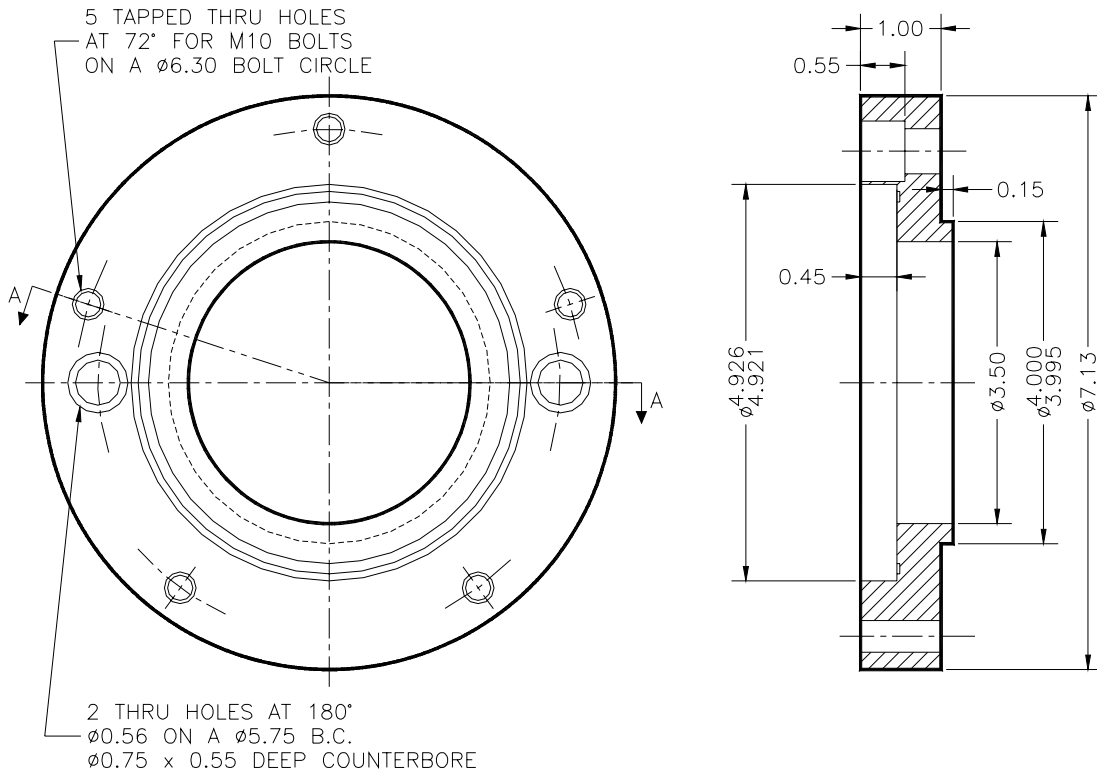

GM1 SAE 'C' 4 BOLT FLANGE

